

# The **Greenskies** range of solar panels from Worcester

Technical and specification information



**NEW**

**Greenskies** solar kits now available to order



CORGI Award winner Energy Efficient Product of the Year 2007

  
**WORCESTER**  
Bosch Group



Worcester, Bosch Group headquarters

## Worcester and you. Making a difference.

Working together for many years, heating professionals and Worcester have been making a real difference in hundreds of thousands of homes across the UK. We are recognised as a market leader in high efficiency, condensing boiler technology and are also committed to providing renewable energy solutions.

As part of the Bosch Group, our products are designed and manufactured to provide the high levels of quality and reliability which are synonymous with the Bosch name throughout the world.

We're a leading British company, employing approximately 2,000 people at our headquarters and manufacturing plants in Worcester and at Clay Cross in Derbyshire, including a nationwide network of over 300 Service Engineers and over 80 technically-trained Field Sales Managers.

As part of Europe's largest supplier of heating products, Worcester, Bosch Group has the UK-based resources and support capability to offer you the value-added solutions we feel you deserve.

*"At Worcester we recognise the vital role you, our customer, has in the specification and installation of 'A' rated, energy efficient appliances in homes across the UK. We will continue to invest in our products, people, facilities and added value services such as training, to give you the support you require in providing a total solution for your customers' comfort."*

Richard Soper,  
Managing Director, Worcester, Bosch Group

### Contents

	<b>Page</b>
The Worcester Greenskies range of solar panels	4 - 7
The inside story	8 - 9
Worcester Greenskies solar panel system layouts	10
Worcester Greenskies cylinder series	11 - 13
Installing Worcester Greenskies FK solar panels	14 - 26
Installation requirements	27
FAQs	28
Worcester Greenskies solar panel package	29
Worcester Greenskies solar panel package ordering	30 - 37
Worcester Greenskies solar panel and Worcester Greenskies cylinder accessories	38 - 41
Worcester Greenskies solar parts ordering	42 - 44
After-sales	45
Worcester training	46 - 47





# Worcester Greenskies solar panels

## Global responsibility for nature and the environment

As part of the Bosch group, Worcester is committed to environmental protection. Product development is prioritised in the interests of the safety of people, the economical use of resources and environmental sustainability.

With this in mind Worcester is proud to offer solar panels for hot water heating which allow the consumer to take advantage of renewable and sustainable energy.

Worcester Greenskies solar panels harness the power in both direct and diffused sunlight and convert the energy to heat for the production of hot water for the home.

The solar panels have been designed as a complement to existing heating systems which use a store of hot water in a cylinder. The existing cylinder is exchanged for a cylinder with two heat exchanger coils; one from the boiler in the property and a second from the solar panels.

The Worcester Greenskies solar panels are a perfect partner to the new range of condensing Greenstar regular and system boilers, with different models available in both oil and gas, which require a separate cylinder for the storage of hot water. When used together a Greenstar boiler and solar system provide a highly efficient system to give heating and hot water comfort.

A typical well sized solar system should provide around 50-70% of the domestic hot water requirements of a home, representing a very worthwhile saving on hot water heating costs. The remaining hot water requirement is provided by the boiler.



## Greenskies solar kits now available to order

See pages 30 – 37 for details

# Worcester Greenskies solar panels range at a glance

## Standard Solar Panels

	Greenskies FKC-1S solar panel	Greenskies FKC-1W solar panel
<b>Orientation</b>	Portrait	Landscape
<b>Gross collector area (m<sup>2</sup>)</b>	2.37	2.37
<b>Absorber area (m<sup>2</sup>)</b>	2.23	2.23
<b>Solar glass transmission (%)</b>	91.5 ± 0.5	91.5 ± 0.5
<b>Absorption (%)</b>	95 ± 2	95 ± 2
<b>Emission (%)</b>	12 ± 2	12 ± 2
<b>Stagnation temperature (°C)</b>	188	188
<b>Weight - empty (kg)</b>	41	42
<b>Max. operating pressure (bar)</b>	6	6

## High Performance Solar Panels

	Greenskies FKT-1S solar panel	Greenskies FKT-1W solar panel
<b>Orientation</b>	Portrait	Landscape
<b>Gross collector area (m<sup>2</sup>)</b>	2.37	2.37
<b>Absorber area (m<sup>2</sup>)</b>	2.23	2.23
<b>Solar glass transmission (%)</b>	91.5 ± 0.5	91.5 ± 0.5
<b>Absorption (%)</b>	95 ± 2	95 ± 2
<b>Emission (%)</b>	5 ± 2	5 ± 2
<b>Stagnation temperature (°C)</b>	202	202
<b>Weight - empty (kg)</b>	44	45
<b>Max. operating pressure (bar)</b>	10	10

Features	Benefits
Efficient collector with 95% absorption rate	Increases performance of panel
Robust panel design	Minimises risk of damage and prolongs service life
Environmentally friendly	All materials recyclable, environmentally conscious manufacture
Quick fitting	Labour and money saving
Easy to fit	Reduces complexity of installation
Simple to use controller	Allows quick setting of functions
Selective coating on absorber	Increases collector performance even on cloudy days
Strong solar glass cover	Protects collector from damage
Larger absorber surface*	Better performance
Lower lift weight*	Easier handling

\*Compared to FK240 panel

# Worcester Greenskies solar panels

## Operation

Worcester Greenskies solar panels form part of a system which remains separate from the boiler heating system.

The panels are mounted on a surface which is selected for its exposure to sunlight and usually connected, via pipe work, to the lower coil of a twin-coil solar cylinder. The energy in the sun's rays is absorbed by the panel and the heat is transferred into the pipe work in the absorber plates. The pipe work is filled with a ready-mixed liquid, containing glycol and water, which is circulated by a pump to the coil in the hot water cylinder. The heat is deposited in the storage cylinder and the glycol returns to the panel to absorb more free solar energy. The system is equipped with a simple unit to control the flow of energy from the panels to the storage cylinder.

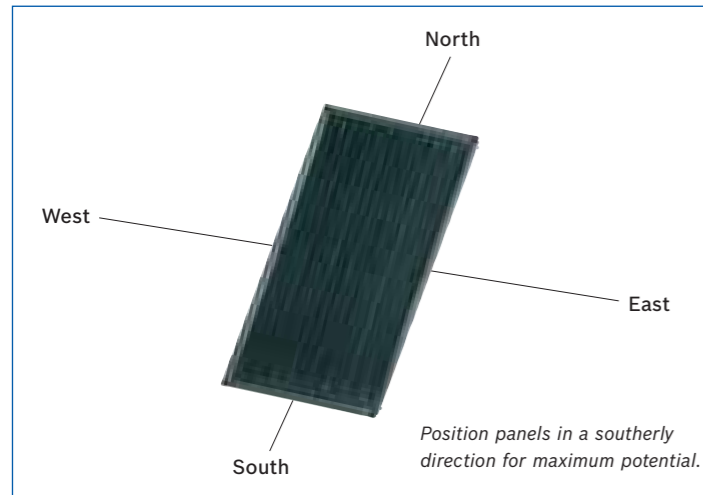

## Application of Worcester Greenskies solar panels

Worcester offers a range of options for a solar water heating solution as an addition to an existing or replacement boiler. The solar panels can also be used for other water heating requirements such as heating of swimming pools.

The panels can be mounted directly onto sloping roofs with a variety of fixings for different roof coverings or onto a frame for flat roofs. In addition, in-roof flashings and wall mounting brackets are available.

The solar panels should be installed in a southerly direction at an angle of between 30° and 45°. Where this is not possible the installation should move towards a westerly facing direction. **East and North facing directions should be avoided.**

## Panel performance

Each Worcester Greenskies collector has a net surface area of 2.23 sq.m. The panels are covered with solar glass which helps the selective coating on the copper collector absorb 95% of the available energy. The panel contains 55mm of mineral wool which contributes to the low 12% emission rating (5% for the FKT panels).

A common question (see the FAQs section for more) about solar in the UK focuses on whether there is enough sunshine available to make solar worthwhile. The usual idea of British weather is of cloudy skies and intermittent sunshine. Worcester's solar panels have been developed with this typical weather in mind and make the most of both direct and diffused sunlight to give a useful annual contribution wherever you are in the UK.

### Solar Radiation in the British Isles

Contrary to popular belief the amount of solar radiation received by the UK is enough for solar water heating to be a viable supplement to existing domestic water heating. Perhaps surprisingly the UK receives 65% of the amount of solar radiation that is received by the south of Spain. The radiation in the UK is made up of direct radiation on sunny days, which accounts for around 40%, and diffused radiation on cloudy days, accounting for 60% of the total.

Summer will provide the largest amount of radiation over the year but a useful contribution will be provided by other seasons.

As an indication, a well sized typical installation will provide the following proportion of the household domestic hot water requirement:

% of requirement fulfilled by solar	
Season	%
Summer	80 - 90
Spring & Autumn	40 - 50
Winter	20 - 30

This translates to over half of the typical annual domestic hot water requirement.

## Controls

The Worcester solar package includes a simple controller (TDS10) which allows the user to select the temperature required at the hot water cylinder. The controller then automatically decides when to run the pump to bring the energy from the panels to the cylinder.

The control uses a simple temperature difference to define when the pump runs. The temperature in the panel must be 8°C higher than the store for the pump to start running. This will continue until the panel temperature gets to 4°C above the store and then the pump will stop.

This ensures that the pump is only running when the benefit from the solar panels is available.



Controller TDS10

## Technical data – Worcester Greenskies solar panel series

Model	Greenskies FKC-1S Solar Panel	Greenskies FKC-1W Solar Panel	Greenskies FKT-1S Solar Panel	Greenskies FKT-1W Solar Panel
<b>Orientation</b>	Portrait	Landscape	Portrait	Landscape
<b>Height (mm)</b>	2,070	1,145	2,070	1,145
<b>Width (mm)</b>	1,145	2,070	1,145	2,070
<b>Depth (mm)</b>	90	90	90	90
<b>Gross collector area (m<sup>2</sup>)</b>	2.37	2.37	2.37	2.37
<b>Aperture area (m<sup>2</sup>)</b>	2.25	2.25	2.25	2.25
<b>Absorber area (m<sup>2</sup>)</b>	2.23	2.23	2.23	2.23
<b>Solar glass transmission (%)</b>	91.5	91.5	91.5	91.5
<b>Stagnation temperature (°C)</b>	188	188	202	202
<b>Fluid content (litres)</b>	0.86	1.25	1.43	1.76
<b>Weight empty (kg)</b>	41	42	44	45
<b>Coating</b>	Highly selective (black chrome)	Highly selective (black chrome)	Highly selective (PVD)	Highly selective (PVD)
<b>Absorption</b>	95% ± 2%	95% ± 2%	95% ± 2%	95% ± 2%
<b>Emission</b>	12% ± 2%	12% ± 2%	5% ± 2%	5% ± 2%
<b>Max. operation pressure (bar)</b>	6	6	10	10
<b>Nominal flow rate (litres/hr)</b>	50	50	50	50
<b>Glass</b>	3.2mm solar safety glass, 91.5% ± 0.5% solar transmission	3.2mm solar safety glass, 91.5% ± 0.5% solar transmission	3.2mm solar safety glass, 91.5% ± 0.5% solar transmission	3.2mm solar safety glass, 91.5% ± 0.5% solar transmission
<b>Frame</b>	UV and weatherproof fibre glass profile with plastic corner	UV and weatherproof fibre glass profile with plastic corner	UV and weatherproof fibre glass profile with plastic corner	UV and weatherproof fibre glass profile with plastic corner
<b>Rear panel</b>	0.6mm aluminium-zinc coated steel sheet	0.6mm aluminium-zinc coated steel sheet	0.6mm aluminium-zinc coated steel sheet	0.6mm aluminium-zinc coated steel sheet
<b>Insulation</b>	55mm mineral wool, high temperature resistant	55mm mineral wool, high temperature resistant	55mm mineral wool, high temperature resistant	55mm mineral wool, high temperature resistant
<b>Fluid for solar circuit</b>	Water-propylene glycol mixture 50/50	Water-propylene glycol mixture 50/50	Water-propylene glycol mixture 50/50	Water-propylene glycol mixture 50/50
<b>Absorber</b>	Copper strip absorber with harp hydraulic, ultrasonic welded	Copper strip absorber with harp hydraulic, ultrasonic welded	Copper strip absorber with double meander hydraulic, ultrasonic welded	Copper strip absorber with double meander hydraulic, ultrasonic welded
<b>Certificates</b>	CE Solar Keymark	CE Solar Keymark	CE Solar Keymark	CE Solar Keymark
<b>Zero-loss collector efficiency</b>	77	77	80.3	80.3
<b>Heat loss co-efficient</b>	3.681	3.681	3.56	3.56

# Worcester Greenskies FKC solar panel – inside story

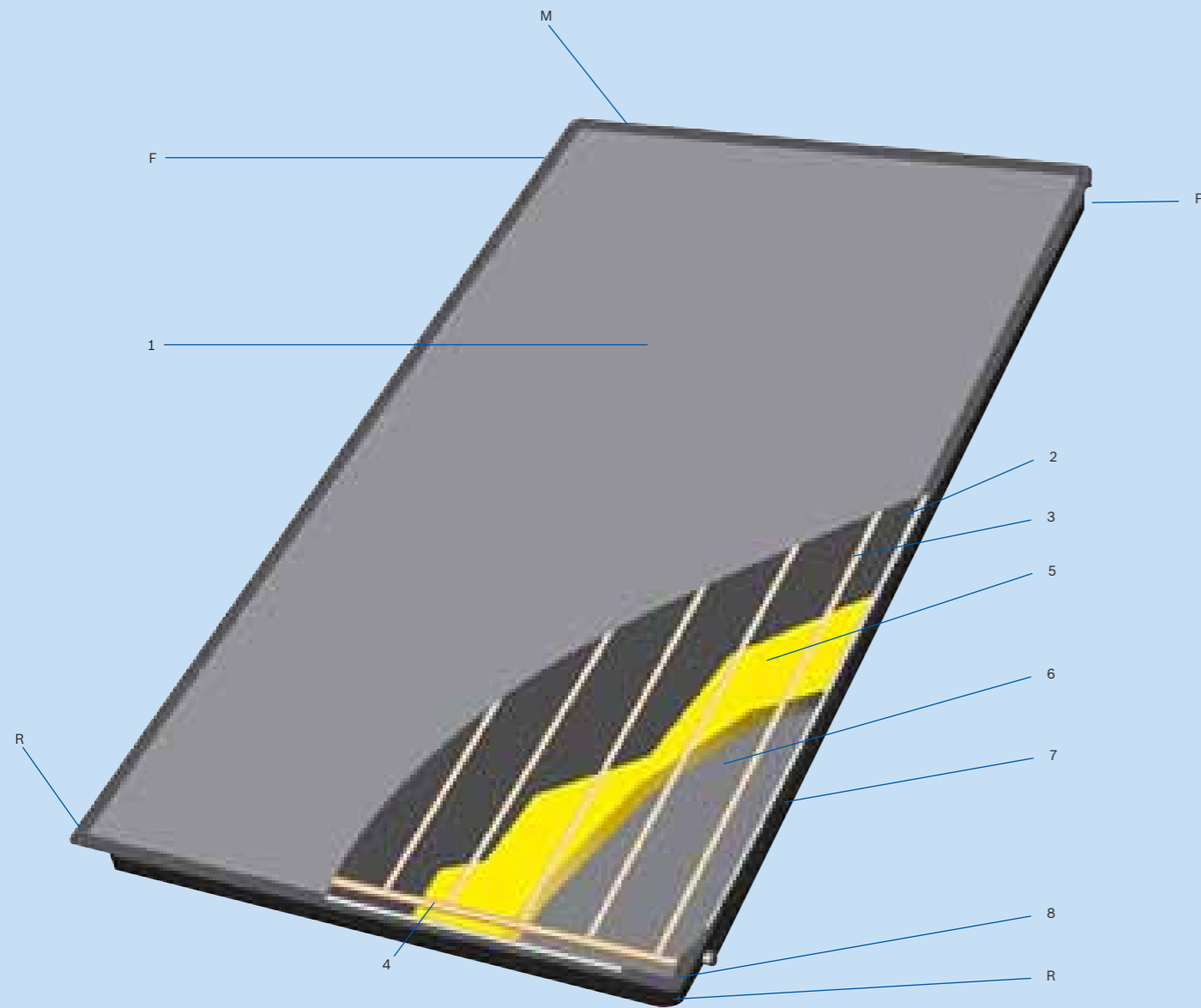

## Key to components

- |                                 |                         |
|---------------------------------|-------------------------|
| F Flow                          | 4. Header Pipe          |
| R Return                        | 5. Insulation           |
| M Socket for Temperature Sensor | 6. Back Plate           |
| 1. Solar Safety Glass           | 7. Fibre Glass Frame    |
| 2. Absorber                     | 8. Plastic Corner Piece |
| 3. Collector Pipework           |                         |

# Worcester Greenskies FKT solar panel – inside story

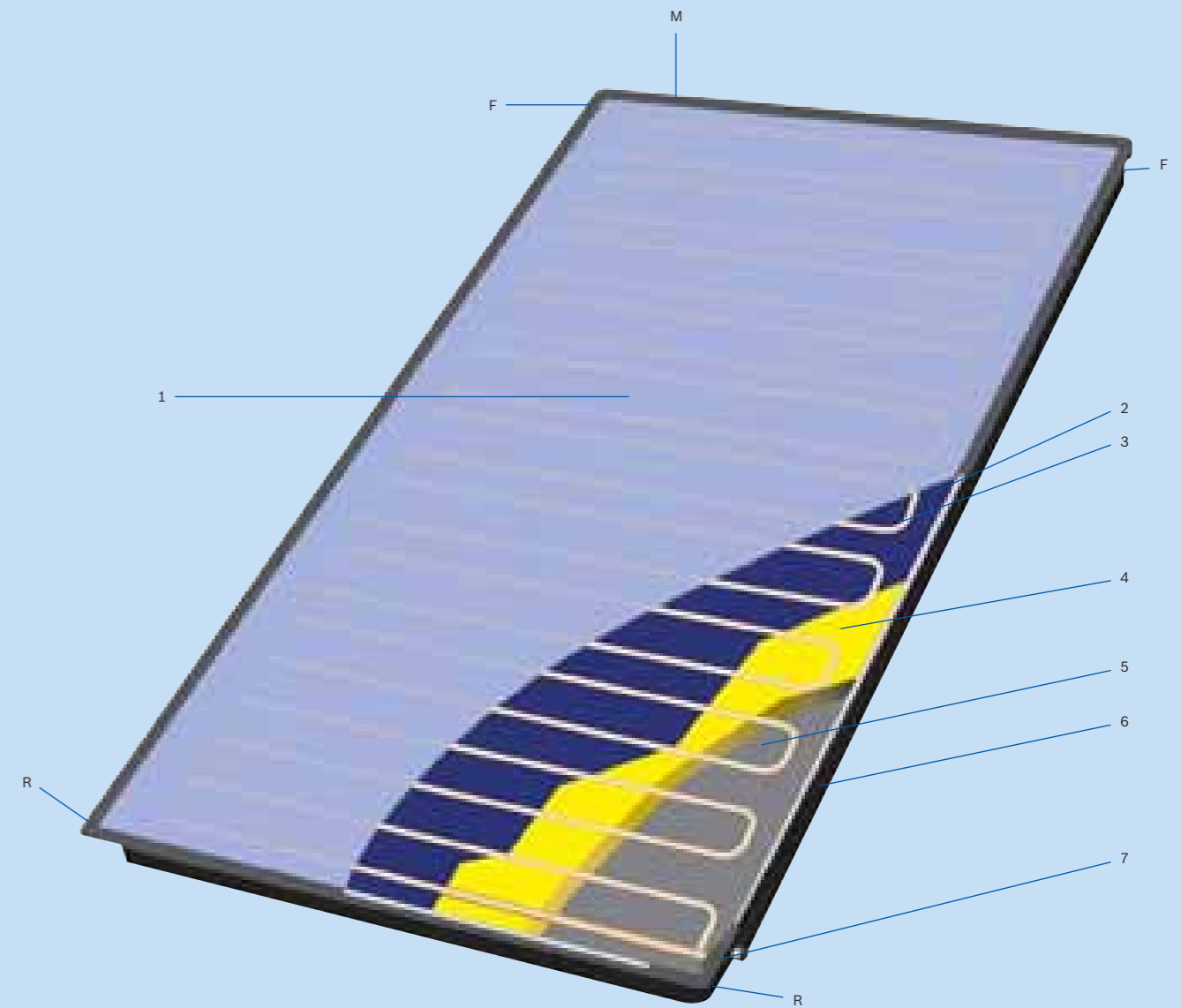

## Key to components

- |                                 |                                      |
|---------------------------------|--------------------------------------|
| F Flow                          | 3. Double Meander Collector Pipework |
| R Return                        | 4. Insulation                        |
| M Socket for Temperature Sensor | 5. Back Plate                        |
| 1. Solar Safety Glass           | 6. Fibre Glass Frame                 |
| 2. Absorber                     | 7. Plastic Corner Piece              |

# Worcester Greenskies solar panel system layouts

## Typical solar system for hot water with twin coil cylinder and conventional boiler

The most common solar system layout uses a twin coil cylinder which is heated by both a boiler (or other heat source) and the solar panels. The solar system and the regular heating system do not come into direct contact with each other and the only shared part is the cylinder.

The solar system has its own pump, expansion vessel, pressure relief valve, air vent and controller.

The Worcester solar package is ideally suited for use with Worcester oil or gas-fired regular or system boilers. These are listed opposite.

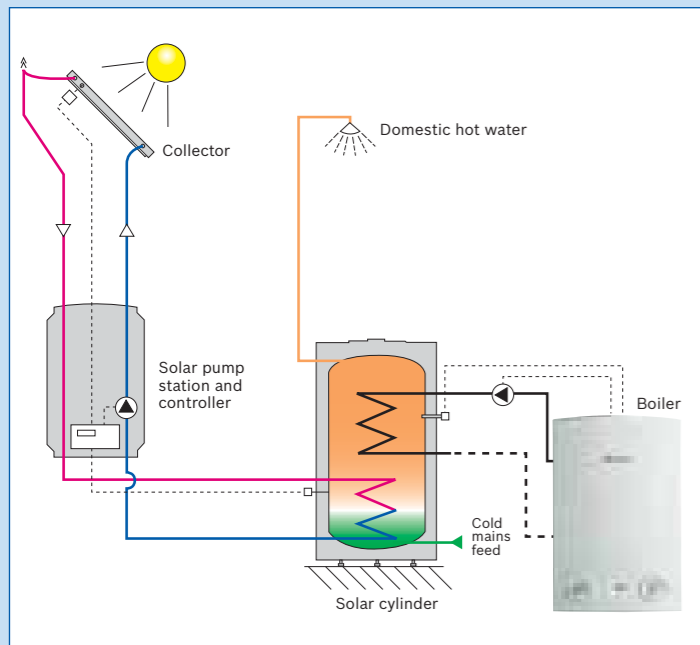

### Worcester boiler compatibility

#### Gas

Greenstar 12i System  
Greenstar 24i System  
Greenstar 12Ri  
Greenstar 15Ri  
Greenstar 18Ri  
Greenstar 24Ri  
Greenstar 30CDi Conventional  
Greenstar 40CDi Conventional  
Greenstar 30CDi System  
Greenstar FS 30CDi Regular  
Greenstar FS 42CDi Regular

#### Oil

Greenstar II HE 12/22  
Greenstar Danesmoor 18/25  
Greenstar Utility 18/25  
Greenstar Utility 32/50  
Greenstar Utility 50/70  
Greenstar Camray Utility 12/18  
Greenstar Camray Utility 18/25  
Greenstar Camray Utility 25/32  
Greenstar Camray Utility System 12/18  
Greenstar Camray Utility System 18/25  
Greenstar Camray Utility System 25/32  
Greenstar Camray External 12/18  
Greenstar Camray External 18/25  
Greenstar Camray External 25/32  
Greenstar Camray (kitchen) 12/18  
Greenstar Camray (kitchen) 18/25  
Greenstar Camray (kitchen) 25/32  
Greenstar Camray (kitchen) System 12/18  
Greenstar Camray (kitchen) System 18/25  
Greenstar Camray (kitchen) System 25/32

Greenstar Danesmoor WM 12/18  
Greenstar Danesmoor WM 18/25  
Danesmoor 12/14 – Kitchen, Utility & System models  
Danesmoor 15/19 – Kitchen, Utility & System models  
Danesmoor 20/25 – Kitchen, Utility & System models  
Danesmoor 26/32 – Kitchen & Utility models  
Danesmoor 32/50 – Utility models  
Danesmoor 50/70 – Utility models  
Danesmoor FS 12/18  
Danesmoor FS 18/25  
Camray 5 40/65 – Kitchen, Utility, System & Utility System models  
Camray 5 65/90 – Kitchen, Utility, System & Utility System models  
Camray 5 95/130 – Kitchen, Utility, System & Utility System models  
Camray 5 150/200 Regular kitchen models  
Camray 5 200/240 Regular kitchen models  
Camray 5 50/70 Internal WM  
Camray 5 50/70 External WM  
Camray 5 External 40/65  
Camray 5 External 65/90

#### Renewable technology – heat pumps\*

Greenstore 6 System  
Greenstore 7 System  
Greenstore 9 System  
Greenstore 11 System

\*In conjunction with Greenstore 180 or 280 Cylinders only.

### Planning

In general the installation of solar panels, as far as planning permission is concerned, is reasonably straight-forward with most local authorities regarding the panels in a similar vein as to flush fitting roof-light windows, where planning

permission may not be required. However, in the absence of the anticipated Permitted Development Act, it is prudent to seek the opinion of the local authority on planning matters prior to starting work on the solar installation. Requirements vary from one authority to the next both with planning permission and building control procedures.

# Worcester Greenskies Cylinder series



## Features

- Inlet control set (pressure reducing valve, strainer, non-return valve and expansion relief valve)
- Temperature & pressure relief valve
- 15mm/22mm Tundish
- Expansion vessel 18 litre or expansion vessel 24 litre
- Wall mounting bracket (for the expansion vessel)
- 22mm DZR compression connections
- 1 x 15mm end feed tee
- Expansion valve (to discharge)
- Expansion vessel hose
- Immersion heater with thermostat and thermal cut out
- 2 x two port valves
- Wiring centre
- Pockets for thermostat points
- 1 x dual thermostat and 1 x high limit thermostat
- Greenskies cylinders are WRAS and BBA approved products to meet G3 Building Regulations

Only for use with one fossil fuel appliance and one solar system (the use of two fossil fuel appliances is not permitted)

The Worcester Greenskies cylinder is a stainless steel unvented twin coil storage cylinder specifically designed to be installed in conjunction with Worcester Greenskies solar system. Should installation with an alternative solar system be considered please seek guidance to ensure compatibility prior to commencing installation.

The Greenskies cylinder is not compatible in an installation utilising two individual boilers.

The Greenskies solar cylinder is made from Duplex stainless steel for excellent corrosion resistance. Greenskies cylinders have a strong rust-proofed steel case and are well insulated with environmentally friendly foam. It is available in a range of 4 sizes from 180 - 300 litres.

The Greenskies cylinder is supplied complete with all the necessary safety and control devices needed to connect to the cold water mains. All are pre-adjusted. High quality controls have been selected to combine high flow rate performance with minimum pressure drop to make Greenskies cylinders perform well in most areas.

Greenskies cylinders are WRAS approved to show compliance with Building Regulations G3 and Part L.

### Storage prior to installation

The Greenskies cylinder should be stored in its original packaging in an upright position in an area free from excessive damp.

## Water supply

The Greenskies cylinder has an optimum working pressure of 3bar (regulated by the inlet control set) and is capable of delivering up to 50 litres per minute. However the performance of any unvented system is only as good as the water supply.

The maximum possible water demand should be assessed, taking into consideration that both hot and cold services are supplied simultaneously from the mains.

The water supply should be checked to ensure it can meet these requirements. If necessary consult the local water company regarding the likely pressure and flow rate availability.

If measuring the water pressure note that a high static (no flow) mains pressure is no guarantee of good flow availability. In a domestic installation 1.5bar and 25 l/m should be regarded as the minimum for a single bathroom application. The maximum mains pressure for the inlet control set is 16bar.

Consideration should be given to upgrading existing 1/2" (15mm) cold mains pipework to a larger size if the recommended minimum pressure/flow rate is not being achieved.

## Siting the unit

The Greenskies cylinder can supply outlets above it or at some distance from it. Site the unit to minimise 'dead leg' distances especially to the point of most frequent use.

Outlets above the Greenskies cylinder will reduce the outlet pressure available by 0.1bar for every 1m of height difference.

The unit should be protected from frost. Particular care is needed if siting in a garage or outbuilding. All exposed pipework must be insulated.

The Greenskies cylinder must be installed upright on a flat base capable of supporting the weight of the cylinder when full (see technical specification section for weights). The minimum recommended cupboard size is 650mm square.

Access for maintenance of the valves should be considered. The immersion heaters are 375mm long and care should be taken that they can be withdrawn for servicing if required. The discharge pipework from the safety valves should fall continuously and terminate safely.

Regarding garage installation, or any situation which is outside of the warm envelope of the building:

Ensure the cylinder is frost protected. Recommended minimum temperature is 5°C. The cylinder should be installed upright on a suitable base, in a vermin-proof area. The installation location should not be liable to flooding or be subject to damp or condensation. All legislation and best practice procedures should be followed at installation.

This product is made from stainless steel and can be recycled when disposing of unit.

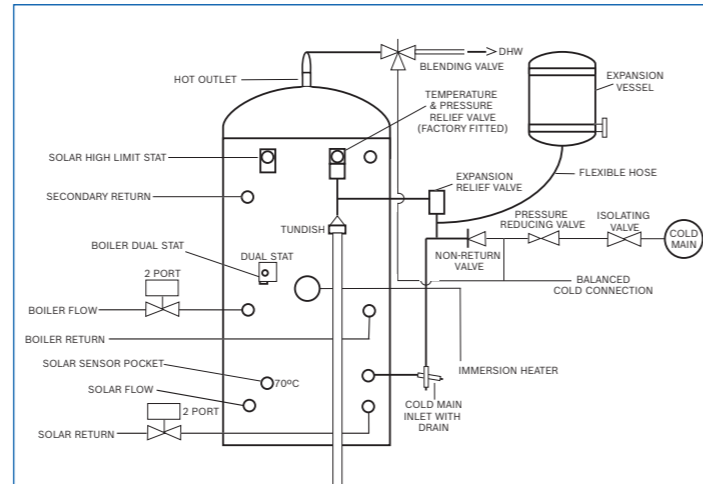

Notes: The pressure reducing valve, non return valve and expansion relief valve are combined together in the inlet control set. On 180 litre sizes there is no dedicated secondary return boss and the secondary return/circuit should be tee'd into the cold feed pipe just above the drain elbow.

## Greenskies solar twin coil cylinder, solar coil connection and wiring

The Worcester Greenskies unvented cylinder is designed to be installed in conjunction with the Greenskies solar package.

The lower coil is connected to the Greenskies solar system and controls as per the Greenskies instructions. Either of the coil connections A & A may be utilised as the flow or return. The solar sensor supplied as part of the Greenskies controls inserts into pocket B.

To meet the requirement of the Building Regulation Part L it is necessary to install the two port valve provided in the return pipework between the cylinder and the solar pump station. The purpose of this valve is to provide system closure should the high limit thermostat activate. The high limit thermostat inserts into pocket F.

The preferred wiring option is when the high limit thermostat closes the two port valve and prevents further input by disconnection of the pump station.

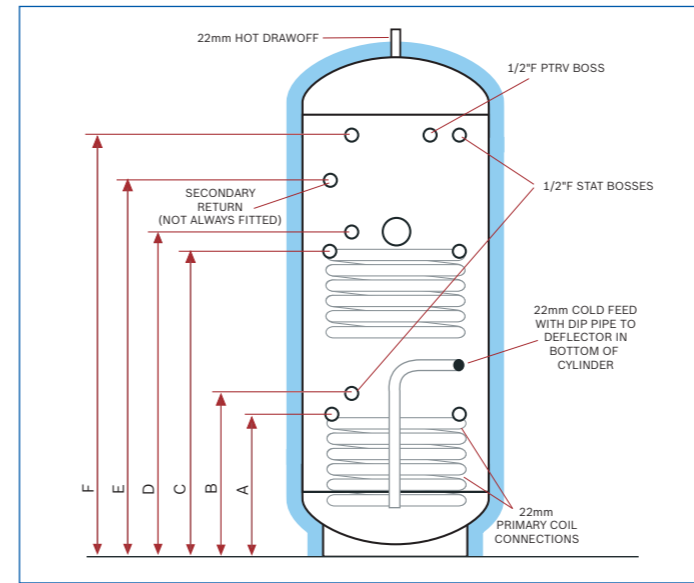

Greenskies Cylinder technical details (mm)				
Key	180	210	250	300
A	365	365	365	365
B	420	420	420	420
C	465	465	465	465
D	N/F	1,000	1,105	1,255
E	825	925	1,050	1,200
F	880	980	1,050	1,200

N/F – Not fitted

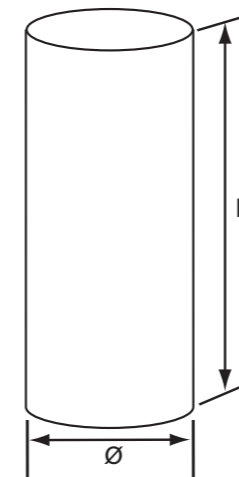

## Product size (mm)

**Greenskies 180 Cylinder** – 1281(h) x 550(dia.)

**Greenskies 210 Cylinder** – 1469(h) x 550(dia.)

**Greenskies 250 Cylinder** – 1719(h) x 550(dia.)

**Greenskies 300 Cylinder** – 2032(h) x 550(dia.)

## Technical data – Worcester Greenskies Cylinder series

Model	Greenskies 180 Cylinder	Greenskies 210 Cylinder	Greenskies 250 Cylinder	Greenskies 300 Cylinder
Height (mm)	1,281	1,469	1,719	2,032
Diameter (mm)	550	550	550	550
Capacity (litres)	180	210	250	300
Weight – empty (kg)	50	55	60	65
Weight – full (kg)	230	265	310	365

Greenskies Cylinder product range	
Product name	Part number
Greenskies 180 Cylinder	7 716 192 554
Greenskies 210 Cylinder	7 716 192 555
Greenskies 250 Cylinder	7 716 192 556
Greenskies 300 Cylinder	7 716 192 557

To make the most of summer sunlight and the higher potential energy gains, a 2 panel system should ideally be combined with a 300 litre cylinder. Where this is not possible, for example where insufficient space is available, a smaller cylinder can be used.

# Installing the Worcester Greenskies FK series of solar panels

Worcester solar panels are now available in two different orientations and in standard (FKC) and high performance (FKT) versions.

The panels are joined by a range of fittings which allow installations on pitched roofs or integrated into the roof. In addition options are available for flat roofs and, with the landscape version, wall mounting.

## Site preparation/portability

In addition to ensuring that the panels are sited in the correct direction and away from sources of shade, particular attention should be paid to site access and the safe installation of the panels. When working at height care should be taken to ensure that the required safety equipment is available and correctly used.

FKC



FKT



Standard on-roof installation



Standard in-roof installation



Standard flat roof installation



Standard wall mounted installation

Refer to pages 30-44 for part number ordering details.

## Standard on-roof installation

### Panel dimensions and clearances

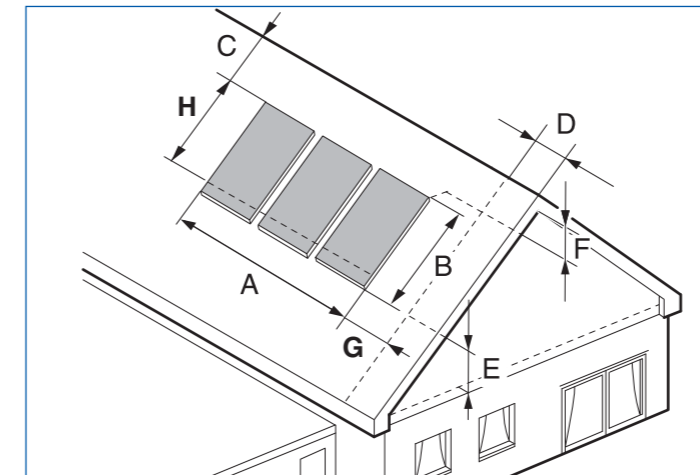

Space required for collector array

Please note the following minimum space requirements.

### Dimension A and B

Area required for the collector array.

### Dimension C

At least two tiles to the roof or chimney. Otherwise there is a risk of damaging the tiles, particularly if the tiles are laid in mortar.

### Dimension D

Roof overhang including gable wall thickness.

### Dimension E

Minimum 30cm for fitting the connection cables in the attic.

### Dimension F

Minimum 40cm for installing the connection cables in the attic (if installing a vent, sufficient space must also be allowed for in the vicinity of the flow outlet).

Please note that the air vent must be the highest point of the system.

### Dimension G

Minimum 50cm left and right of the collector array for the connection cables under the roof.

### Dimension H

Dimension H is 1,900mm (1,000mm for landscape collectors) and is the minimum distance from the upper edge of the collector to the lower profile rail, which is installed first.

Space required for portrait installed collectors (including facing panels all around)

No. of collectors	Dimension A (m)	Dimension B (m)
2	2.32	2.07
3	3.49	2.07
4	4.66	2.07
5	5.83	2.07
6	7.06	2.07
7	8.17	2.07
8	9.34	2.07
9	10.51	2.07

Space required for landscape installed collectors (including facing panels all around)

No. of collectors	Dimension A (m)	Dimension B (m)
2	4.17	1.15
3	6.26	1.15
4	8.36	1.15
5	10.45	1.15
6	12.55	1.15
7	14.64	1.15
8	16.74	1.15
9	18.61	1.15

### Assembling: on-roof installation for portrait collectors

Portrait collectors are suitable for use on building heights up to 20m with the standard roof bar kits and extensions. A maximum snow load of 2kN/m<sup>2</sup> is permissible.

- Building height: up to 20m
- Snow loads: up to 2.0kN/m<sup>2</sup>

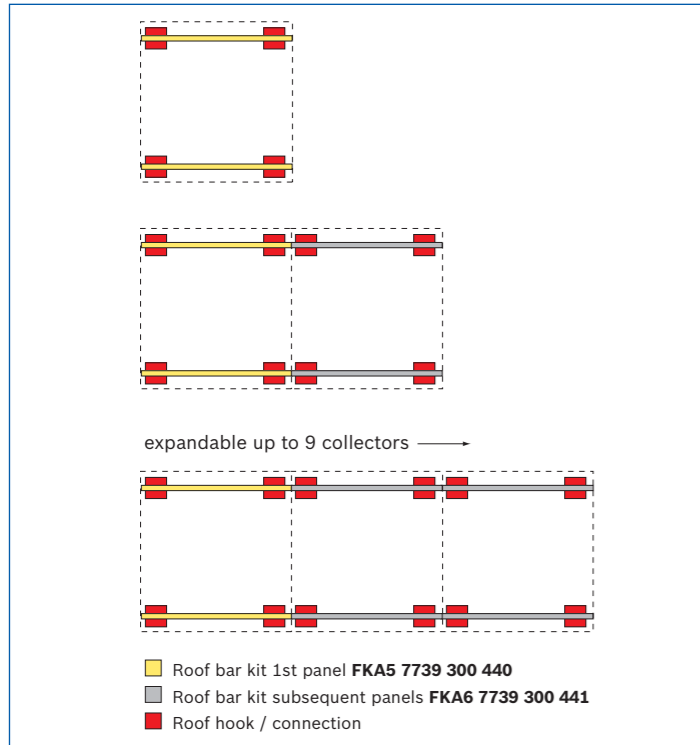

On building heights above 20m or for snow loads of between 2kN/m<sup>2</sup> and 3.1kN/m<sup>2</sup> the following accessories are required.

- Building height: > 20m – 100m
- Snow loads: > 2kN/m<sup>2</sup> - 3.1kN/m<sup>2</sup>

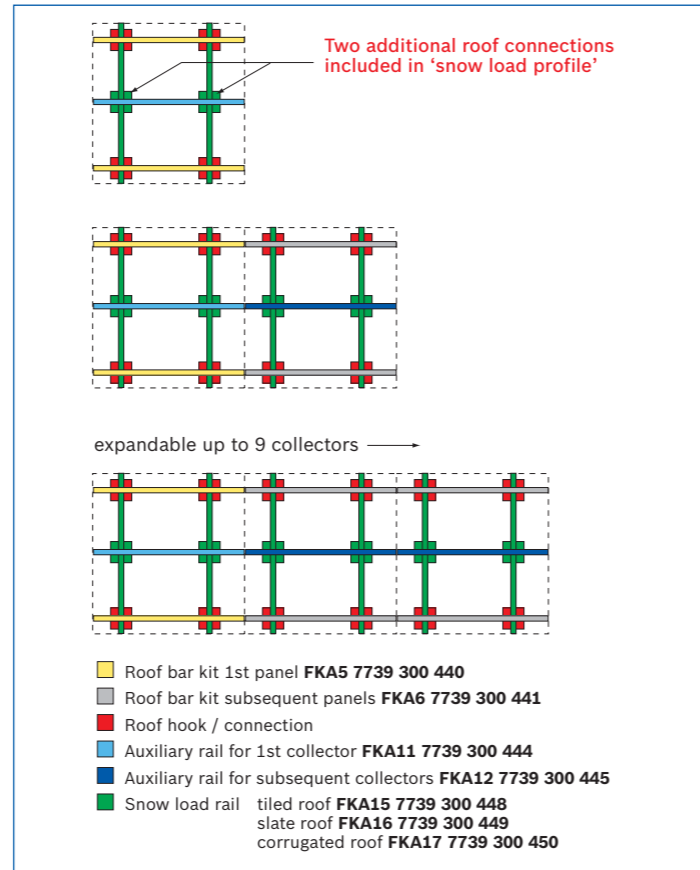

### Assembling: on-roof installation for landscape collectors

When using landscape panels a maximum building height of 20m and a maximum snow load of 2kN/m<sup>2</sup> is permissible. Landscape installation is also not possible if roof battens are more than 420mm apart. In-roof kits are suggested as an alternative in these circumstances.

- Building height: up to 20m
- Snow loads: 20kN/m<sup>2</sup>
- Batten distance: < 420mm

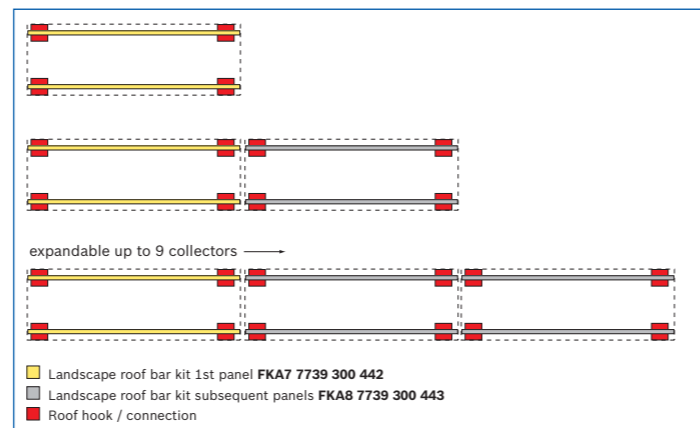

### Panel support assembly

Each panel is secured onto a pair of rails which can be assembled on the ground and then raised to the roof. The rails can then be mounted on the roof hooks, which are available to suit various roof and tile types.

In addition, the Worcester Greenskies solar panels are available with a support kit for installation on flat surfaces, offering greater flexibility for installation.

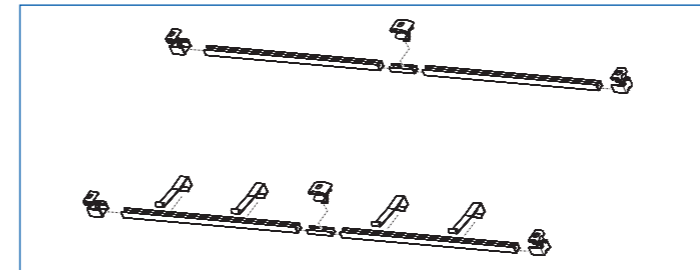

Pre-assembled profile rails for two adjacent collectors

### Connecting profile rails

Individual rails are joined with a rail connector into which the rails slide for an easy connection.

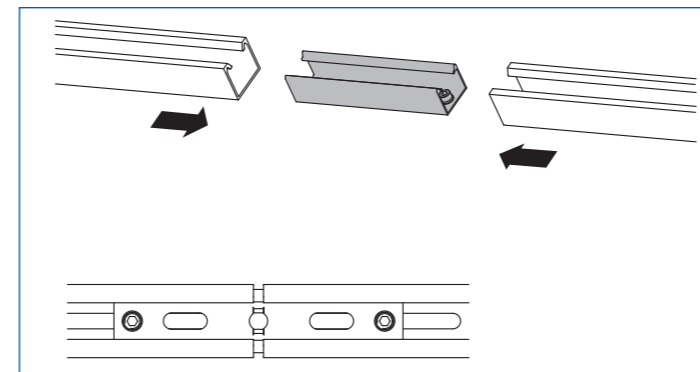

Rail connection

# Standard in-roof installation

## Panel dimensions and clearances

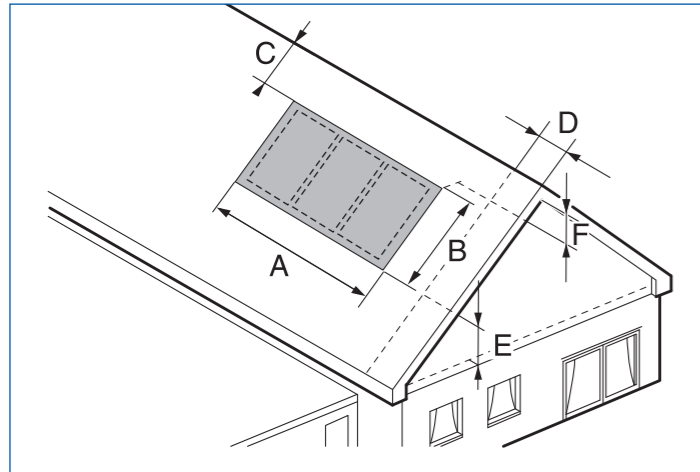

Space required for collector array

### Space required for portrait installed collectors (including facing panels all around)

No. of collectors	Dimension A (m)	Dimension B (m)
2	2.67	2.80
3	3.84	2.80
4	5.01	2.80
5	6.18	2.80
6	7.41	2.80
7	8.52	2.80
8	9.69	2.80
9	10.86	2.80

### Space required for landscape installed collectors (including facing panels all around)

No. of collectors	Dimension A (m)	Dimension B (m)
2	4.52	1.87
3	6.61	1.87
4	8.71	1.87
5	10.80	1.87
6	12.90	1.87
7	14.99	1.87
8	17.09	1.87
9	18.96	1.87

Please note the following minimum space requirements.

### Dimension A and B

Area required for the collector array, including facing panels.

### Dimension C

At least two tiles to the roof or chimney. Otherwise there is a risk of damaging the tiles, particularly if the tiles are laid in mortar.

### Dimension D

Roof overhang including gable wall thickness.

### Dimension E

Minimum 30cm for fitting the connection cables in the attic.

### Dimension F

Minimum 40cm for fitting the connection cables in the attic.

Please note that the air vent must be the highest point of the system.

## Portrait

### Assembling: roof integration – extension to the side for portrait collectors

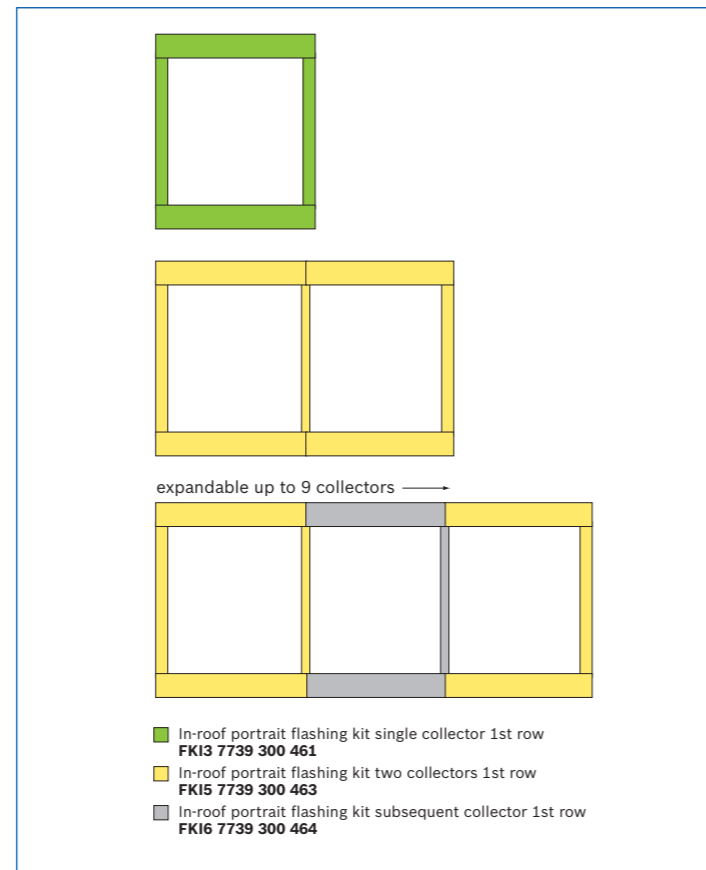

### Assembling: roof integration – extension above for portrait collectors

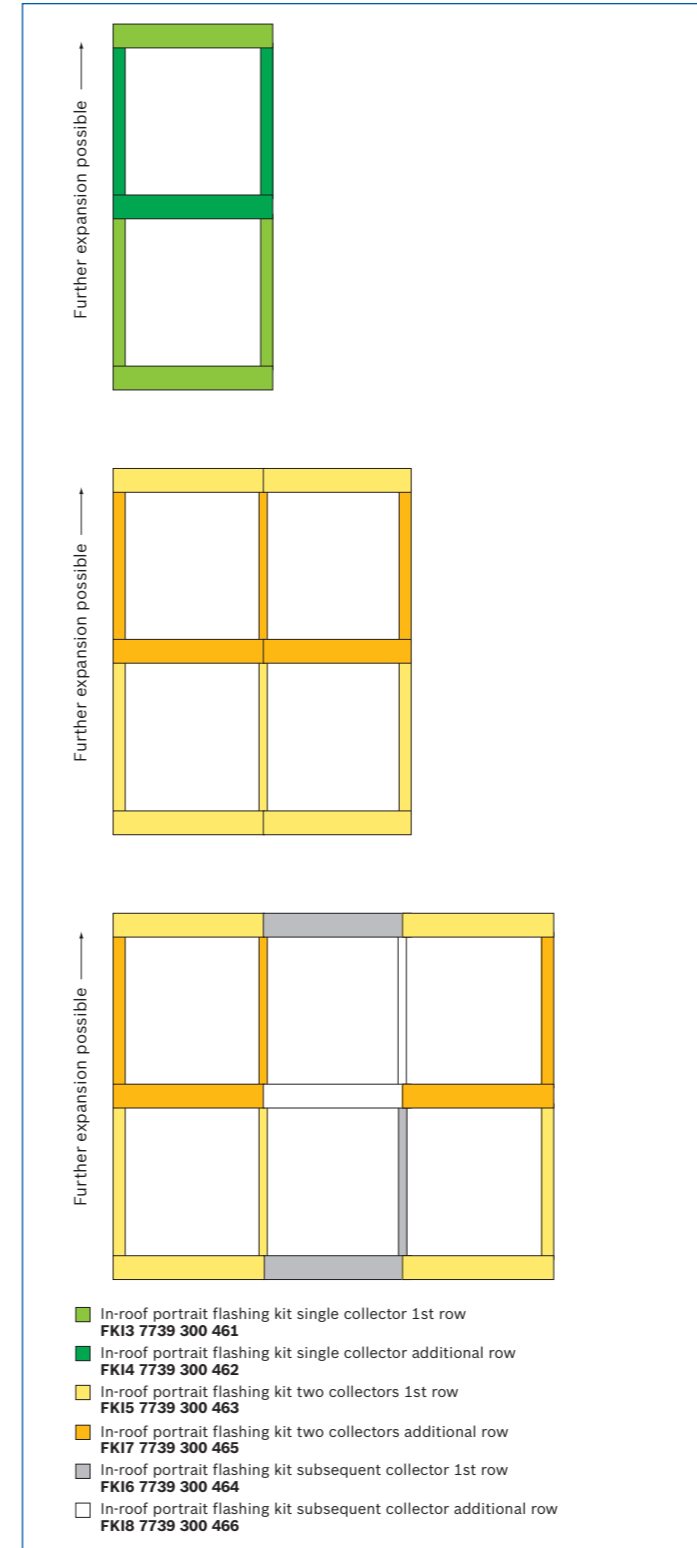

## Landscape

### Assembling: roof integration – extension to the side for landscape collectors

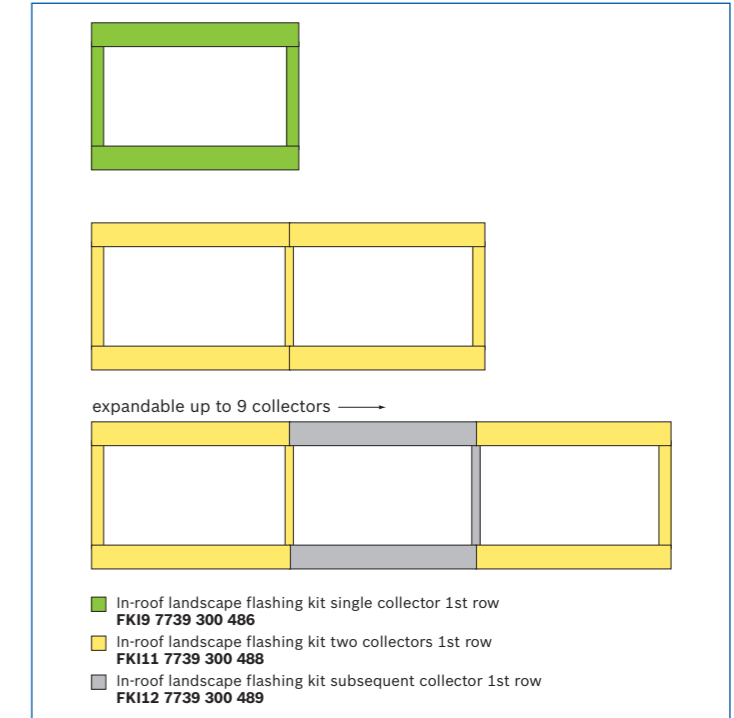

**Assembling: roof integration – extension above for landscape collectors**

- In-roof landscape flashing kit single collector 1st row  
**FKI9 7739 300 486**
- In-roof landscape flashing kit single collector additional row  
**FKI10 7739 300 487**
- In-roof landscape flashing kit two collectors 1st row  
**FKI11 7739 300 488**
- In-roof landscape flashing kit two collectors additional row  
**FKI13 7739 300 490**
- In-roof landscape flashing kit subsequent collector 1st row  
**FKI12 7739 300 489**
- In-roof landscape flashing kit subsequent collector additional row  
**FKI14 7739 300 491**

**Standard flat roof installation**

**Panel dimensions and clearances**

The minimum spacing between the collector arrays is determined by the angle of inclination of the collector.

Note: When using multi-row arrays, note that the clearance (X) between the arrays must be large enough to avoid shadows falling over adjacent collectors.

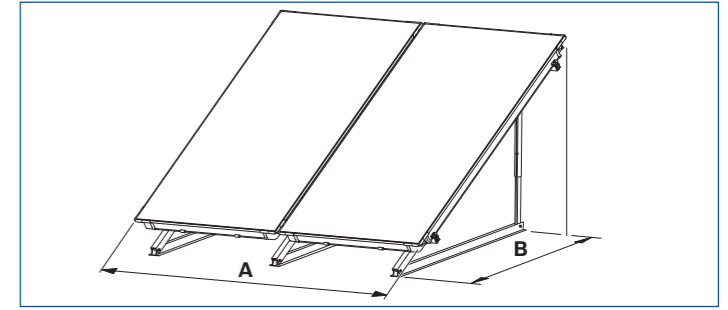

Space requirements – collector array – portrait panels

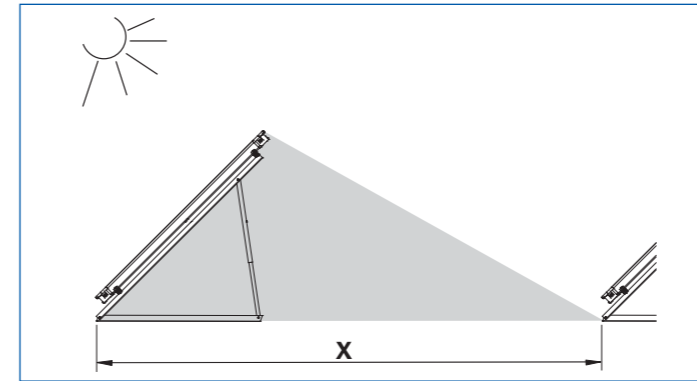

Shadow clearance X

Clearance between collector arrays		
Collector angle of inclination	Portrait panel clearance (m) X	Landscape panel clearance (m) X
25°	4.74	2.63
30°	5.18	2.87
35°	5.58	3.09
40°	5.94	3.29
45°	6.26	3.46
50°	6.52	3.61
55°	6.74	3.73
60°	6.90	3.82

Dependency of clearance on the angle of incidence and the minimum altitude of the sun (17°)

Space requirements for portrait collectors	
No. of collectors	Dimension A (m)
2	2.34
3	3.51
4	4.68
5	5.85
6	7.02
7	8.19
8	9.36
9	10.53

Space requirements for portrait collectors	
Angle of inclination	Dimension B (m)
25°	1.84
30°	1.75
35°	1.68
40°	1.58
45°	1.48
50°	1.48
55°	1.48
60°	1.48

Space requirements for landscape collectors	
No. of collectors	Dimension A (m)
2	4.18
3	6.28
4	8.38
5	10.48
6	12.58
7	14.68
8	16.78
9	18.88

Space requirements for landscape collectors	
Angle of inclination	Dimension B (m)
25°	1.06
30°	1.02
35°	0.96
40°	0.91
45°	0.85
50°	0.85
55°	0.85
60°	0.85

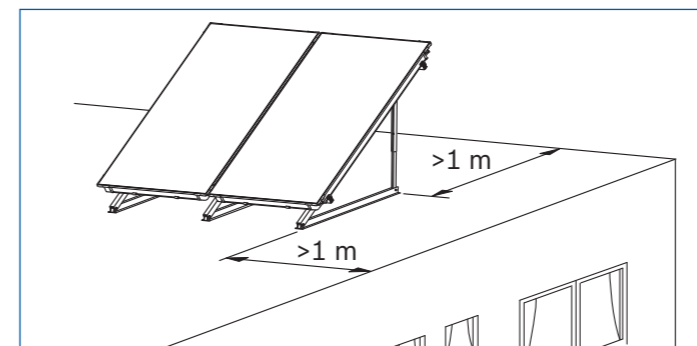

Distance from edge of roof

Allow sufficient installation space for the different forms of installation (landscape, portrait).

These dimensions (above) relate to the roof surface area which must be available.

The quoted dimensions are simply the width of the collector array. In addition, allow at least 0.5m on either side of the collector array for pipework.

## Portrait

### Assembling: portrait flat roof support, fixed by loading tray set

- Building height:  $\leq 20\text{m}$
- Snow loads:  $\leq 2\text{kN/m}^2$

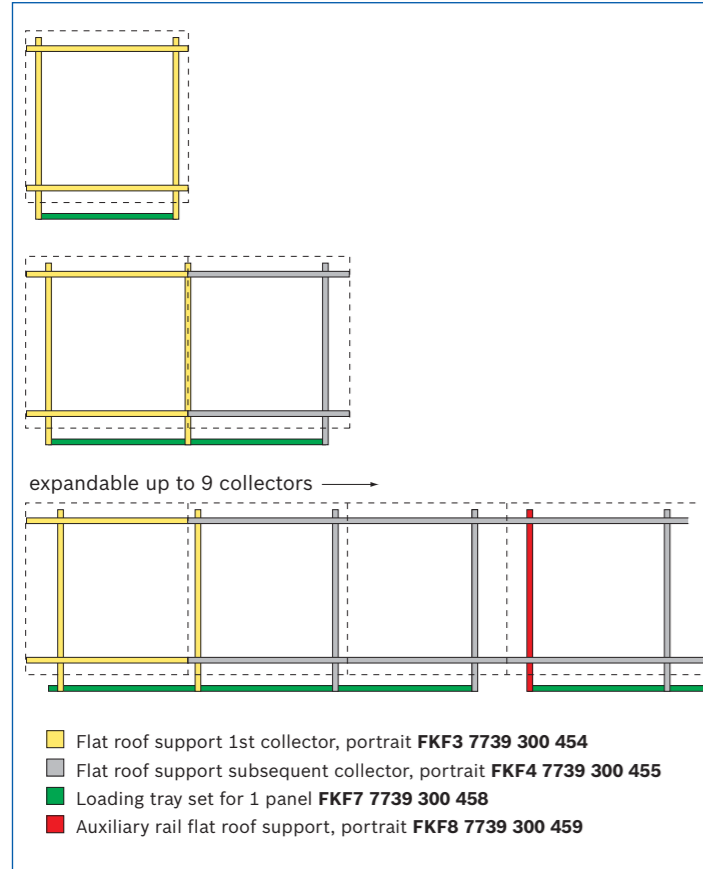

### Using auxiliary rail for flat roof support (portrait) fixed by loading tray set

Case of operation:

- Building height:  $\leq 20\text{m}$
- Snow loads:  $\leq 2\text{kN/m}^2$

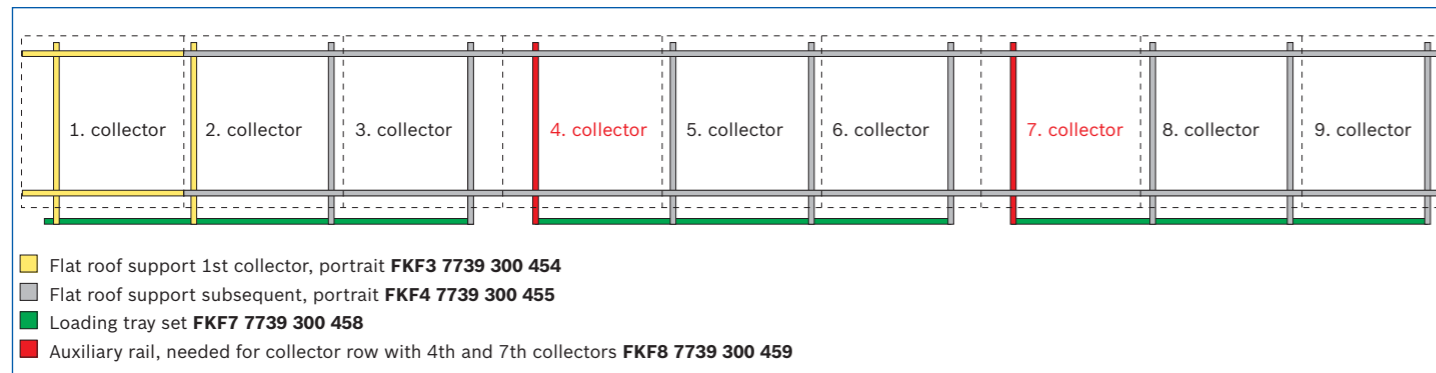

- Building height:  $> 20\text{m} - 100\text{m}$   
(with additional fixing by cable)

- Snow loads:  $> 2\text{kN/m}^2 - 3.8\text{kN/m}^2$

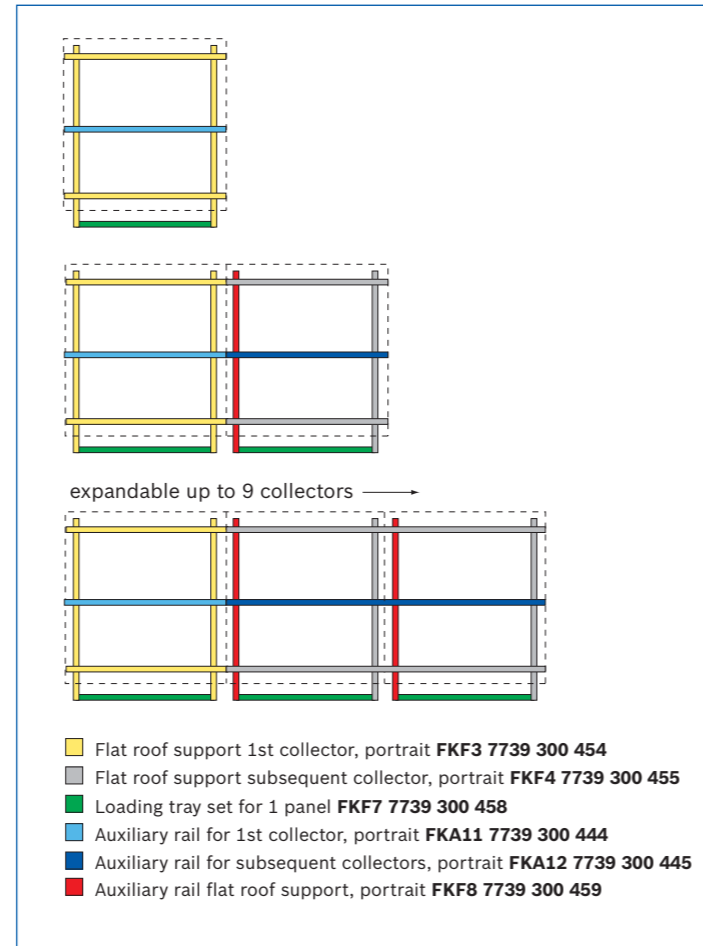

## Portrait

### Assembling: flat roof support (portrait) secured by conventional fixings

- Building height:  $\leq 20\text{m}$
- Snow loads:  $\leq 2\text{kN/m}^2$

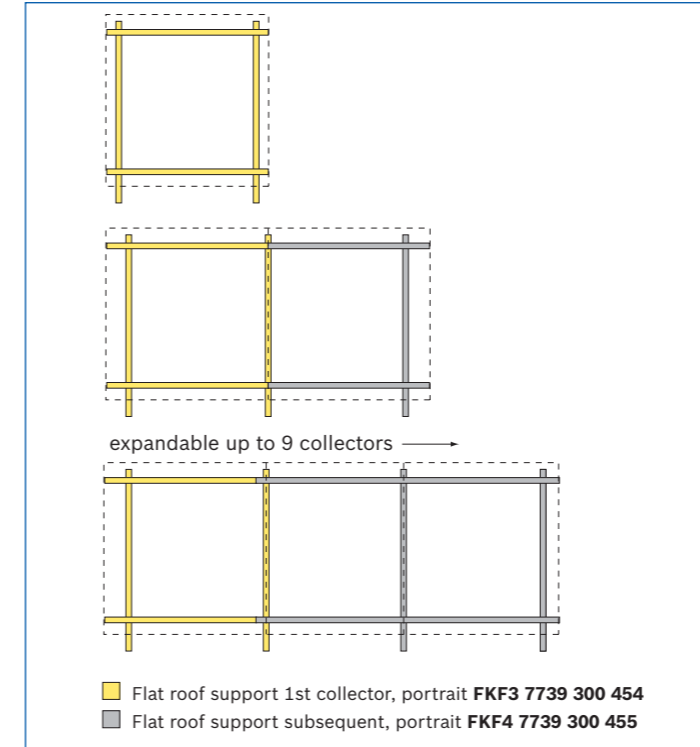

- Building height:  $> 20\text{m} - 100\text{m}$
- Snow loads:  $> 2\text{kN/m}^2 - 3.8\text{kN/m}^2$

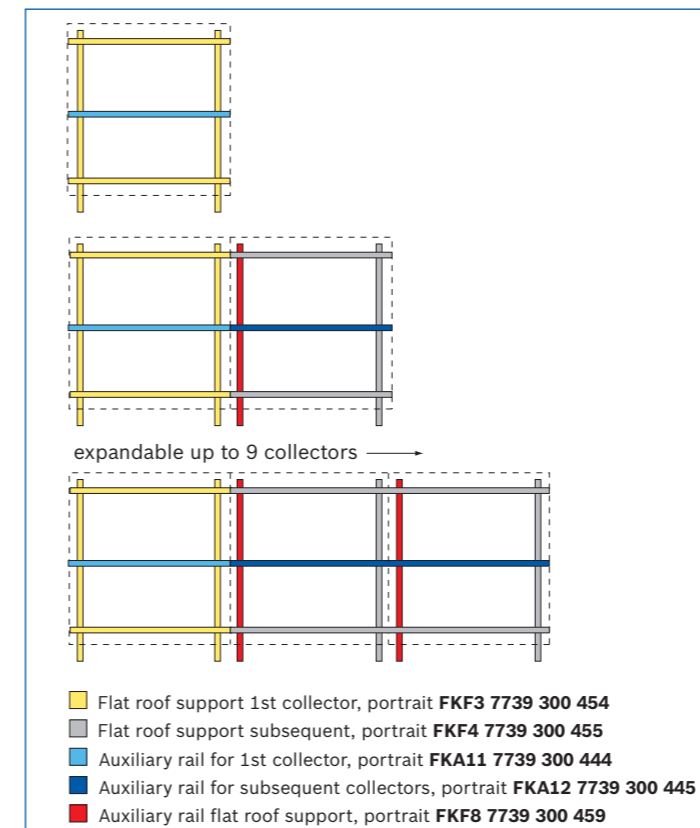

## Landscape

### Assembling: flat roof support (landscape) fixed by loading tray set

- Building height:  $\leq 20\text{m}$
- Snow loads:  $\leq 2\text{kN/m}^2$

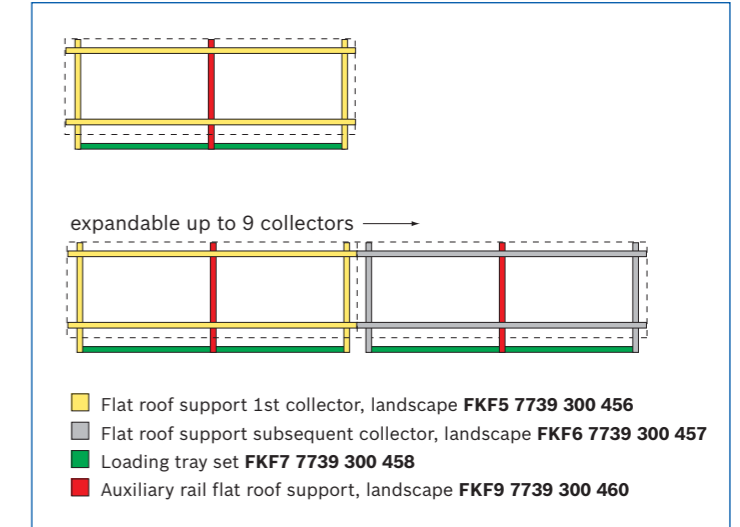

- Building height:  $> 20\text{m} - 100\text{m}$   
(with additional fixing by cable)

- Snow loads:  $> 2\text{kN/m}^2 - 3.8\text{kN/m}^2$

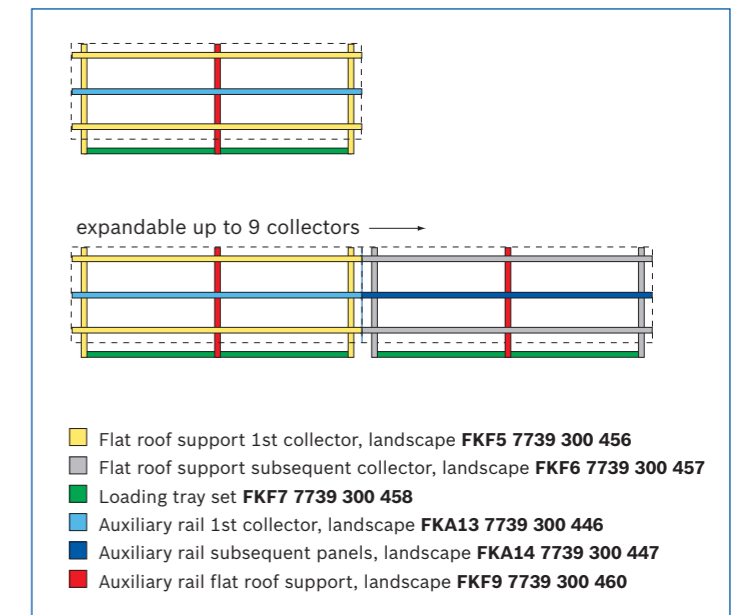

## Landscape

### Assembling: flat roof support (landscape) secured by conventional fixings

- Building height:  $\leq 20\text{m}$
- Snow loads:  $\leq 2\text{kN/m}^2$

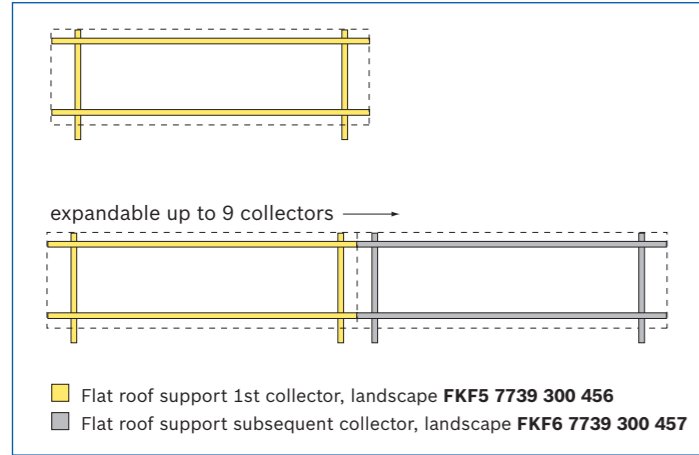

- Building height:  $> 20\text{m} - 100\text{m}$
- Snow loads:  $> 2\text{kN/m}^2 - 3.8\text{kN/m}^2$

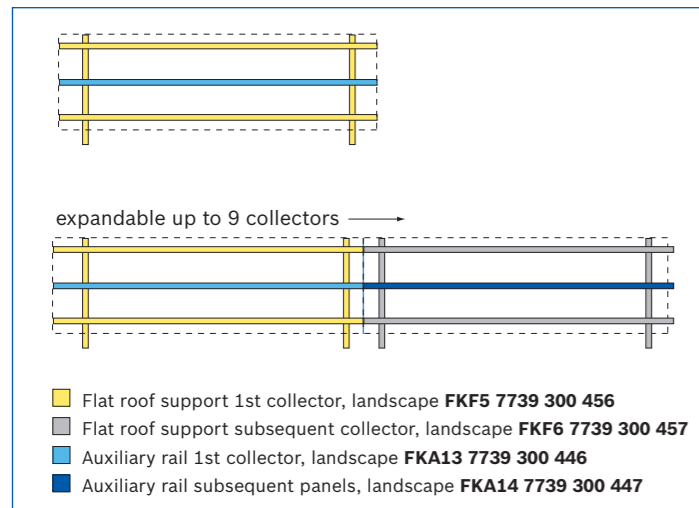

## Standard wall-mounted installation

Greenskies solar panels can be mounted on vertical walls using the standard landscape flat roof stands in the appropriate orientation.

### Panel dimensions and clearances

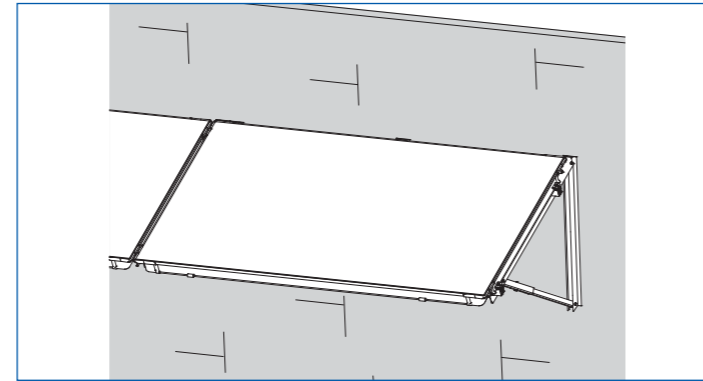

Wall mounting support

The landscape collector braces can also be used for wall-mounted installation.

Only landscape collector braces are allowed for wall-mounted installation.

- Collectors may only be installed on walls of buildings with a height up to 20m (wind velocity = 129 km/h) and a snow load of up to 2.0kN/m<sup>2</sup>.
- Each collector brace must be fastened using the holes provided by 3 fixings according to the details in the installation manual.
- Install only on a sealed, windproof outside wall.
- Before installing the wall mounting support, check the load-bearing capability of the fixing wall (i.e. of the wall base). If necessary, ask a structural engineer for assistance.
- Never modify the wall mounting structure.
- Never place objects in the space underneath the wall mounting support.

Space requirements for landscape collectors	
No. of collectors	Dimension (width (m))
2	4.18
3	6.28
4	8.38
5	10.48
6	12.58
7	14.68
8	16.78
9	18.88

### Assembling: wall mounted installation for landscape collector types

- Installation height:  $\leq 20\text{m}$
- Snow loads:  $\leq 2\text{kN/m}^2$

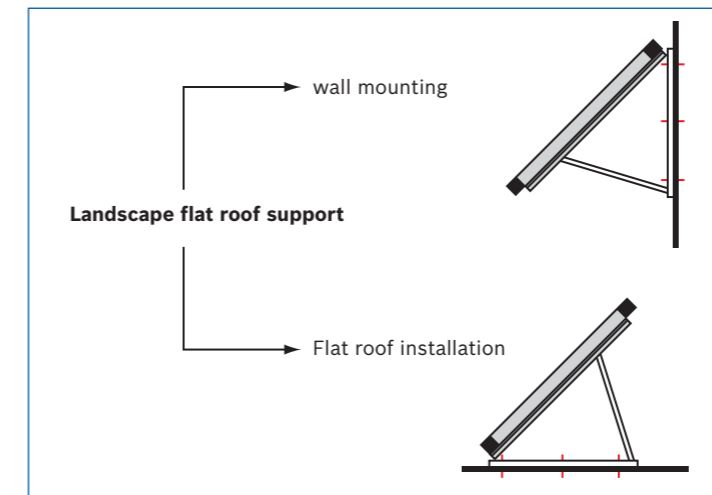
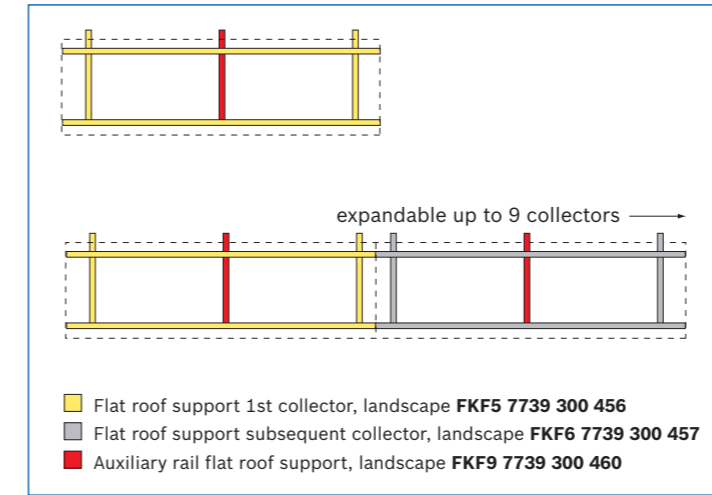

# Panel pipework connections

## Pipework connections – FKC panels

Worcester Greenskies FKC solar panels are equipped with simple push-fit connections which speed installation and, with bespoke flexible hoses, aid the routing of pipework into the roofspace. Once inside the property the system should be run in copper pipe.

Flexible hose connections are secured with a simple quick release clip which closes automatically and allows the time required for pipework on the roof to be reduced.

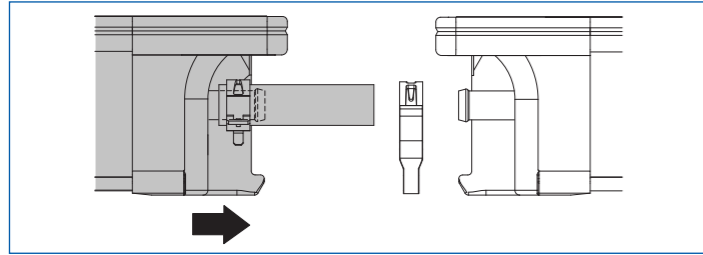

Subsequent collectors in series also use the flexible hose connection method to enable arrays to be plumbed-in with ease.

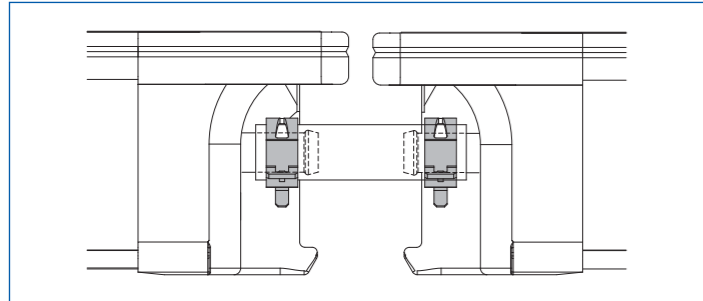

The second panel (of a two panel array) can be added easily with push-fit connections and quick-release clips.

Specific connector sets are available for on-roof, integrated roof and flat roof installations.

## Pipework connections – FKT panels

Worcester Greenskies FKT solar panels feature push-fit stainless steel connections, which for on-roof installations are pre-insulated.

The hydraulic connections are secured using a simple stainless steel connector clip which further reduces the time required for pipework.

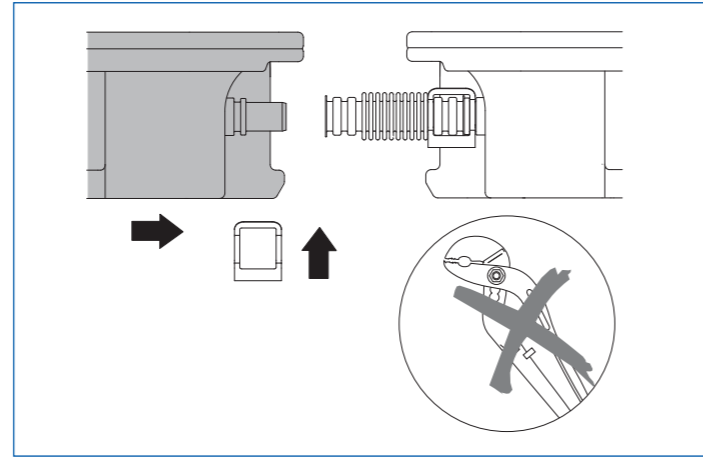

Subsequent collectors in the series also use the stainless steel connection method to enable arrays to be plumbed-in with ease.

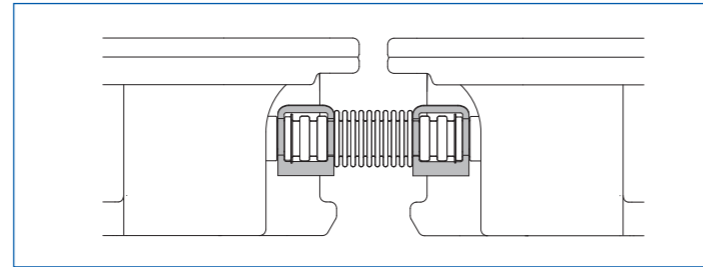

The second panel (of a two panel array) can be added easily with push-fit connectors and connector clips.

Specific connector sets are available for on-roof, integrated roof and flat roof installations.

# Installation requirements

The installation of the Worcester solar system must be carried out in accordance with the relevant requirements for safety, current Wiring Regulations, local Building Regulations, Building Standards (Scotland), (Consolidation) Regulations and Bylaws of the local water company and Health and Safety document No. 63S (Electricity at Work Regulations 1989). It should be in accordance with the relevant recommendations of the following British Standards and Regulations:

BS 5918:1989

The Health and Safety at Work Act 1974

The Management of Health and Safety at Work Regulations 1999

The Construction (Health, Safety and Welfare) Regulations 1996

The Construction (Design and Management) Regulations 1994

The Lifting Operations and Lifting Equipment Regulations 1998, and any other relevant regulations in force at this time.

The manufacturer's notes must not be taken in any way as overriding statutory regulations.

## Electricity supply

A 3 amp fused spur (complying with BS 1363) with a double pole isolator with a contact separation of 3mm in all poles supplying the controller should be used. The controller must be earthed.

## Glycol heat transfer liquid

Worcester Greenskies solar panels and system components should be used only with the recommended heat transfer liquid – Tyfocor®L manufactured by Tyforop Chemie GmbH, available from stockists of Worcester Greenskies solar panels.

The heat transfer liquid uses a proven concentration of antifreeze and water to give protection against freezing and provide optimum performance from the panels and system.

## Hot water blending valve

It is recommended a thermostatic blending valve be used in conjunction with the solar cylinder in order to guard against the high hot water temperatures which the system can provide.

## Insulation

Exposed pipework should be insulated according to the high temperatures that the panels are able to generate. Insulation rated to 150°C must be used. Suitable insulation is available from Armacell UK Ltd., Mars Street, Oldham, Lancashire OL9 6LY.

## Pressure relief valve

The AGS2 Solar pump station in the Worcester Greenskies solar package is equipped with a 3bar pressure relief valve which should be connected to pipe work terminating in a suitable container. An empty canister of heat transfer fluid can be used for this purpose. Alternatively, the pipework can be run to a foul drain or soil stack.

## Warranty

Worcester is proud to offer a guarantee of 2 years on the Greenskies solar panels and a 2 years' warranty on other components providing the registration card has been completed and returned.

Greenskies twin-coil hot water cylinders offer a 25 years' guarantee with a 2 years' warranty on components.

# Homeowner FAQs

## Q. What is sustainable energy?

A. Sustainable energy is best thought of as energy which can be replenished within a human lifetime and which causes no long-term damages to the environment. Solar energy, wind energy and geothermal energy, amongst others, are all self-sustaining. They all have sources that cannot be depleted. Extended use of these energy sources aids the conservation of other non-renewable energy sources such as fossil fuels.

## Q. How does solar technology work?

A. The idea behind technologies which use solar energy is to harness the freely available rays from the sun in a useful form. The technology used for solar water heating is simple and effective. The basic principle uses an absorber plate which is heated by the sun's rays. This heat is collected in a transfer liquid which is in turn used in a heat exchanger to heat water.

## Q. What if there is no sun or it is a cloudy day?

A. Special coatings are available on the absorber plates which allow the collector to absorb energy from diffused as well as direct sunlight. This means the panel can still yield results on days when there are clouds in the sky.

## Q. Is there any Government funding available?

A. The Department for Business Enterprise & Regulatory Reform (BERR), formerly known as the DTI, is funding an initiative called the Low Carbon Building Programme which entitles home owners and not-for-profit organisations to financial help with a solar system when installed by an approved installer.

## Q. Do I have to pay VAT for installing solar panels?

A. The VAT on solar systems varies depending on who is installing it. DIY solar systems carry 17.5% VAT. A system which is installed by a professional VAT registered installer carries 5% VAT. For further information visit: [www.hm-treasury.gov.uk](http://www.hm-treasury.gov.uk)

## Q. Do I still need a boiler?

A. Solar heating on a normal domestic scale in the UK will provide around 50-70% of the average annual household hot water requirements. Although the system may provide most of the hot water required in summer, the winter results, due to the lower intensity of the sun and the shorter daylight hours, will be reduced. As such the householder will need a boiler (or suitable alternative) to make up the difference in domestic hot water requirement and for the central heating of the house.

## Q. Do I need to have a particular type of roof for Solar installation?

A. In the UK the best orientation for solar panels is facing due south and tilted at between 30 and 45° from the horizontal. The gains available will reduce as the orientation moves away from due south. A variety of brackets and frames are available for solar systems to suit different roof types (pitched and flat) and different types of roof tiles.

# Worcester Greenskies typical system

A typical Worcester Greenskies solar system will contain:

1. Solar panels
2. AGS2 solar pump station
3. TDS10 solar controller
4. Automatic air vent
5. Expansion vessel
6. Heat transfer fluid (glycol)
7. Choice of roof fixings



# Solar package ordering

## Worcester Greenskies solar panel kits

FKC-1S standard 2 panel portrait kit on roof  
Part number: 7 716 150 000

**NEW**

Kit contains:

<p><b>Solar collector Worcester FKC-1S</b></p>  <p>Worcester Part No. 7 747 025 748 Quantity: 2</p>	<p><b>Solar pump station</b></p>  <p>Worcester Part No. 7 739 300 377 Quantity: 1</p>	<p><b>TDS10 solar controller</b></p>  <p>Worcester Part No. 7 739 300 378 Quantity: 1</p>	<p><b>On roof FKA6 portrait exten 1 coll</b></p>  <p>Worcester Part No. 7 739 300 441 Quantity: 1</p>
<p><b>Solar fluid 25L</b></p>  <p>Worcester Part No. 7 739 300 057 Quantity: 1</p>	<p><b>On roof FKA5 portrait basic 1 coll</b></p>  <p>Worcester Part No. 7 739 300 440 Quantity: 1</p>	<p><b>Expansion vessel connector</b></p>  <p>Worcester Part No. 7 739 300 331 Quantity: 1</p>	<p><b>Connection set FS55 for FKC on roof</b></p>  <p>Worcester Part No. 7 747 002 438 Quantity: 1</p>
<p><b>Expansion vessel 25L</b></p>  <p>Worcester Part No. 7 739 300 119 Quantity: 1</p>	<p><b>Roof connection FKA3 for tile/plain tile</b></p>  <p>Worcester Part No. 7 739 300 436 Quantity: 2</p>	<p><b>Air vent set ELT5 for FKC</b></p>  <p>Worcester Part No. 7 739 300 432 Quantity: 1</p>	

## Worcester Greenskies solar panel kits

FKC-1S standard 2 panel portrait kit in roof  
Part number: 7 716 150 001

**NEW**

Kit contains:

<p><b>Solar collector Worcester FKC-1S</b></p>  <p>Worcester Part No. 7 747 025 748 Quantity: 2</p>	<p><b>Roof integrated FKI5 portrait basic 2 coll tile</b></p>  <p>Worcester Part No. 7 739 300 463 Quantity: 1</p>	<p><b>Solar pump station</b></p>  <p>Worcester Part No. 7 739 300 377 Quantity: 1</p>	<p><b>TDS10 solar controller</b></p>  <p>Worcester Part No. 7 739 300 378 Quantity: 1</p>
<p><b>Solar fluid 25L</b></p>  <p>Worcester Part No. 7 739 300 057 Quantity: 1</p>	<p><b>Expansion vessel connector</b></p>  <p>Worcester Part No. 7 739 300 331 Quantity: 1</p>	<p><b>Connection set FS56 for FKC roof integrated</b></p>  <p>Worcester Part No. 7 747 002 439 Quantity: 1</p>	<p><b>Expansion vessel 25L</b></p>  <p>Worcester Part No. 7 739 300 119 Quantity: 1</p>
<p><b>Air vent set ELT5 for FKC</b></p>  <p>Worcester Part No. 7 739 300 432 Quantity: 1</p>			

# Worcester Greenskies solar panel kits

FKC-1W standard 2 panel landscape kit on roof  
Part number: 7 716 150 002

NEW

Kit contains:

<p><b>Solar collector Worcester FKC-1W</b></p>  <p>Worcester Part No. 7 747 025 749 Quantity: 2</p>	<p><b>Solar pump station</b></p>  <p>Worcester Part No. 7 739 300 377 Quantity: 1</p>	<p><b>TDS10 solar controller</b></p>  <p>Worcester Part No. 7 739 300 378 Quantity: 1</p>	<p><b>On roof FKA8 landscape exten 1 coll</b></p>  <p>Worcester Part No. 7 739 300 443 Quantity: 1</p>
<p><b>Solar fluid 25L</b></p>  <p>Worcester Part No. 7 739 300 057 Quantity: 1</p>	<p><b>On roof FKA7 landscape basic 1 coll</b></p>  <p>Worcester Part No. 7 739 300 442 Quantity: 1</p>	<p><b>Expansion vessel connector</b></p>  <p>Worcester Part No. 7 739 300 331 Quantity: 1</p>	<p><b>Connection set FS55 for FKC on roof</b></p>  <p>Worcester Part No. 7 747 002 438 Quantity: 1</p>
<p><b>Expansion vessel 25L</b></p>  <p>Worcester Part No. 7 739 300 119 Quantity: 1</p>	<p><b>Roof connection FKA3 for tile/plain tile</b></p>  <p>Worcester Part No. 7 739 300 436 Quantity: 2</p>	<p><b>Air vent set ELT5 for FKC</b></p>  <p>Worcester Part No. 7 739 300 432 Quantity: 1</p>	

# Worcester Greenskies solar panel kits

FKC-1W standard 2 panel landscape kit in roof  
Part number: 7 716 150 003

NEW

Kit contains:

<p><b>Solar collector Worcester FKC-1W</b></p>  <p>Worcester Part No. 7 747 025 749 Quantity: 2</p>	<p><b>Roof integrated FKI11 landscape basic 2 coll tile</b></p>  <p>Worcester Part No. 7 739 300 488 Quantity: 1</p>	<p><b>Solar pump station</b></p>  <p>Worcester Part No. 7 739 300 377 Quantity: 1</p>	<p><b>TDS10 solar controller</b></p>  <p>Worcester Part No. 7 739 300 378 Quantity: 1</p>
<p><b>Solar fluid 25L</b></p>  <p>Worcester Part No. 7 739 300 057 Quantity: 1</p>	<p><b>Expansion vessel connector</b></p>  <p>Worcester Part No. 7 739 300 331 Quantity: 1</p>	<p><b>Connection set FS56 for FKC roof integrated</b></p>  <p>Worcester Part No. 7 747 002 439 Quantity: 1</p>	<p><b>Expansion vessel 25L</b></p>  <p>Worcester Part No. 7 739 300 119 Quantity: 1</p>
<p><b>Air vent set ELT5 for FKC</b></p>  <p>Worcester Part No. 7 739 300 432 Quantity: 1</p>			

# Worcester Greenskies solar panel kits

**FKT-1S high 2 panel portrait kit on roof**  
**Part number: 7 716 150 004**

**NEW**

Kit contains:

<p><b>Solar collector Worcester FKT-1S</b></p>  <p><b>Worcester Part No. 7 747 025 750 Quantity: 2</b></p>	<p><b>Solar pump station</b></p>  <p><b>Worcester Part No. 7 739 300 377 Quantity: 1</b></p>	<p><b>TDS10 solar controller</b></p>  <p><b>Worcester Part No. 7 739 300 378 Quantity: 1</b></p>	<p><b>On roof FKA6 portrait exten 1 coll</b></p>  <p><b>Worcester Part No. 7 739 300 441 Quantity: 1</b></p>
<p><b>Solar fluid 25L</b></p>  <p><b>Worcester Part No. 7 739 300 057 Quantity: 1</b></p>	<p><b>On roof FKA5 portrait basic 1 coll</b></p>  <p><b>Worcester Part No. 7 739 300 440 Quantity: 1</b></p>	<p><b>Expansion vessel connector</b></p>  <p><b>Worcester Part No. 7 739 300 331 Quantity: 1</b></p>	<p><b>Connection-set FS59 for FKT on roof integrated</b></p>  <p><b>Worcester Part No. 7 747 002 442 Quantity: 1</b></p>
<p><b>Expansion vessel 25L</b></p>  <p><b>Worcester Part No. 7 739 300 119 Quantity: 1</b></p>	<p><b>Roof connection FKA3 for tile/plain tile</b></p>  <p><b>Worcester Part No. 7 739 300 436 Quantity: 2</b></p>	<p><b>Air vent set ELT6 for FKT</b></p>  <p><b>Worcester Part No. 7 739 300 433 Quantity: 1</b></p>	

# Worcester Greenskies solar panel kits

**FKT-1S high 2 panel portrait kit in roof**  
**Part number: 7 716 150 005**

**NEW**

Kit contains:

<p><b>Solar collector Worcester FKT-1S</b></p>  <p><b>Worcester Part No. 7 747 025 750 Quantity: 2</b></p>	<p><b>Roof integrated FKI5 portrait basic 2 coll tile</b></p>  <p><b>Worcester Part No. 7 739 300 463 Quantity: 1</b></p>	<p><b>Solar pump station</b></p>  <p><b>Worcester Part No. 7 739 300 377 Quantity: 1</b></p>	<p><b>TDS10 solar controller</b></p>  <p><b>Worcester Part No. 7 739 300 378 Quantity: 1</b></p>
<p><b>Solar fluid 25L</b></p>  <p><b>Worcester Part No. 7 739 300 057 Quantity: 1</b></p>	<p><b>Expansion vessel connector</b></p>  <p><b>Worcester Part No. 7 739 300 331 Quantity: 1</b></p>	<p><b>Connection-set FS59 for FKT on roof integrated</b></p>  <p><b>Worcester Part No. 7 747 002 442 Quantity: 1</b></p>	<p><b>Expansion vessel 25L</b></p>  <p><b>Worcester Part No. 7 739 300 119 Quantity: 1</b></p>
<p><b>Air vent set ELT6 for FKT</b></p>  <p><b>Worcester Part No. 7 739 300 433 Quantity: 1</b></p>			

# Worcester Greenskies solar panel kits

**FKT-1W high 2 panel landscape kit on roof**  
**Part number: 7 716 150 006**

**NEW**

Kit contains:

<p><b>Solar collector Worcester FKT-1W</b></p>  <p><b>Worcester Part No. 7 747 025 751 Quantity: 2</b></p>	<p><b>Solar pump station</b></p>  <p><b>Worcester Part No. 7 739 300 377 Quantity: 1</b></p>	<p><b>TDS10 solar controller</b></p>  <p><b>Worcester Part No. 7 739 300 378 Quantity: 1</b></p>	<p><b>On roof FKA8 landscape exten 1 coll</b></p>  <p><b>Worcester Part No. 7 739 300 443 Quantity: 1</b></p>
<p><b>Solar fluid 25L</b></p>  <p><b>Worcester Part No. 7 739 300 057 Quantity: 1</b></p>	<p><b>On roof FKA7 landscape basic 1 coll</b></p>  <p><b>Worcester Part No. 7 739 300 442 Quantity: 1</b></p>	<p><b>Expansion vessel connector</b></p>  <p><b>Worcester Part No. 7 739 300 331 Quantity: 1</b></p>	<p><b>Connection-set FS59 for FKT on roof integrated</b></p>  <p><b>Worcester Part No. 7 747 002 442 Quantity: 1</b></p>
<p><b>Expansion vessel 25L</b></p>  <p><b>Worcester Part No. 7 739 300 119 Quantity: 1</b></p>	<p><b>Roof connection FKA3 for tile/plain tile</b></p>  <p><b>Worcester Part No. 7 739 300 436 Quantity: 2</b></p>	<p><b>Air vent set ELT6 for FKT</b></p>  <p><b>Worcester Part No. 7 739 300 433 Quantity: 1</b></p>	

# Worcester Greenskies solar panel kits

**FKT-1W high 2 panel landscape kit in roof**  
**Part number: 7 716 150 007**

**NEW**

Kit contains:

<p><b>Solar collector Worcester FKT-1W</b></p>  <p><b>Worcester Part No. 7 747 025 751 Quantity: 2</b></p>	<p><b>Roof integrated FKI11 landscape basic 2 coll tile</b></p>  <p><b>Worcester Part No. 7 739 300 488 Quantity: 1</b></p>	<p><b>Solar pump station</b></p>  <p><b>Worcester Part No. 7 739 300 377 Quantity: 1</b></p>	<p><b>TDS10 solar controller</b></p>  <p><b>Worcester Part No. 7 739 300 378 Quantity: 1</b></p>
<p><b>Solar fluid 25L</b></p>  <p><b>Worcester Part No. 7 739 300 057 Quantity: 1</b></p>	<p><b>Expansion vessel connector</b></p>  <p><b>Worcester Part No. 7 739 300 331 Quantity: 1</b></p>	<p><b>Connection-set FS59 for FKT on roof integrated</b></p>  <p><b>Worcester Part No. 7 747 002 442 Quantity: 1</b></p>	<p><b>Expansion vessel 25L</b></p>  <p><b>Worcester Part No. 7 739 300 119 Quantity: 1</b></p>
<p><b>Air vent set ELT6 for FKT</b></p>  <p><b>Worcester Part No. 7 739 300 433 Quantity: 1</b></p>			

# Worcester Greenskies solar panel accessories

**Solar collector  
Worcester FKC-1S**



**Worcester Part No.  
7 747 025 748**

**Solar collector  
Worcester FKC-1W**



**Worcester Part No.  
7 747 025 749**

**Solar collector  
Worcester FKT-1S**



**Worcester Part No.  
7 747 025 750**

**Solar collector  
Worcester FKT-1W**



**Worcester Part No.  
7 747 025 751**

**Roof connection FKA4 for  
corrugated/tin roof**



**Worcester Part No.  
7 739 300 439**

**Auxiliary rail FKA11  
portrait basic 1 coll**



**Worcester Part No.  
7 739 300 444**

**Auxiliary rail FKA12  
portrait exten 1 coll**



**Worcester Part No.  
7 739 300 445**

**Snow load profile FKA15  
portrait tile/plain tile**



**Worcester Part No.  
7 739 300 448**

**Connection set FS55  
for FKC on roof**



**Worcester Part No.  
7 747 002 438**

**Connection set FS56  
for FKC roof integrated**



**Worcester Part No.  
7 747 002 439**

**Connection set FS57  
for FKC flat roof**



**Worcester Part No.  
7 747 002 440**

**Connection set FS58  
for FKT flat roof**



**Worcester Part No.  
7 747 002 441**

**Snow load profile FKA16  
portrait slate/shingle**



**Worcester Part No.  
7 739 300 449**

**Snow load profile FKA17  
portrait corrugated/tin roof**



**Worcester Part No.  
7 739 300 450**

**On roof FKA7 landscape  
basic 1 coll**



**Worcester Part No.  
7 739 300 442**

**On roof FKA8 landscape  
exten 1 coll**



**Worcester Part No.  
7 739 300 443**

**Connection-set FS59 for  
FKT on roof integrated**



**Worcester Part No.  
7 747 002 442**

**Serial connection set  
FS6 for FKC**



**Worcester Part No.  
7 739 300 434**

**Air vent set  
ELT5 for FKC**



**Worcester Part No.  
7 739 300 432**

**Serial connection set  
FS7 for FKT**



**Worcester Part No.  
7 739 300 435**

**Roof integrated FKI3  
portrait basic 1 coll tile**



**Worcester Part No.  
7 739 300 461**

**Roof integrated FKI4  
portrait 2 row 1 coll tile**



**Worcester Part No.  
7 739 300 462**

**Roof integrated FKI9  
landscape basic 1 coll tile**



**Worcester Part No.  
7 739 300 486**

**Roof integrated FKI10  
landscape 2 row 1 coll tile**



**Worcester Part No.  
7 739 300 487**

**Air vent set  
ELT6 for FKT**



**Worcester Part No.  
7 739 300 433**

**On roof FKA5 portrait  
basic 1 coll**



**Worcester Part No.  
7 739 300 440**

**On roof FKA6 portrait  
exten 1 coll**



**Worcester Part No.  
7 739 300 441**

**Roof connection FKA3  
for tile/plain tile**



**Worcester Part No.  
7 739 300 436**

**Roof integrated FKI5  
portrait basic 2 coll tile**



**Worcester Part No.  
7 739 300 463**

**Roof integrated FKI6  
portrait exten tile**



**Worcester Part No.  
7 739 300 464**

**Roof integrated FKI7  
portrait 2 row 2 coll tile**

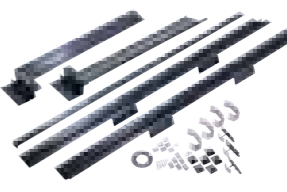

**Worcester Part No.  
7 739 300 465**

**Roof integrated FKI8  
portrait 2 row exten tile**



**Worcester Part No.  
7 739 300 466**

# Worcester Greenskies solar panel accessories

Roof integrated FK111 landscape basic 2 coll tile



Worcester Part No.  
7 739 300 488

Roof integrated FK112 landscape exten tile

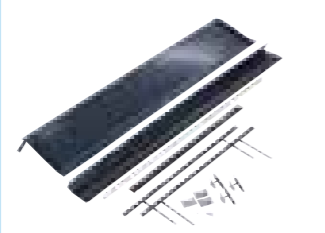

Worcester Part No.  
7 739 300 489

Roof integrated FK113 landscape 2 row 2 coll tile



Worcester Part No.  
7 739 300 490

Roof integrated FK114 landscape 2 row exten tile



Worcester Part No.  
7 739 300 491

Flat roof support FKF3 portrait basic 1 coll

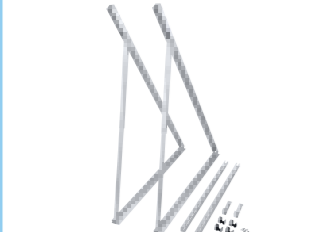

Worcester Part No.  
7 739 300 454

Flat roof support FKF4 portrait exten 1 coll

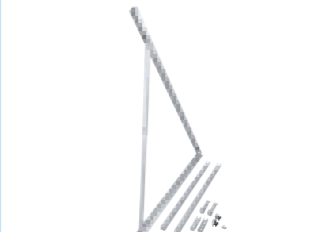

Worcester Part No.  
7 739 300 455

Loading tray set FKF7 for 1 coll



Worcester Part No.  
7 739 300 458

Auxiliary rail FKF8 portrait 1 coll flat roof



Worcester Part No.  
7 739 300 459

Auxiliary rail FKF9 landscape 1 coll flat roof



Worcester Part No.  
7 739 300 460

Auxiliary rail FKA13 landscape basic 1 coll



Worcester Part No.  
7 739 300 446

Auxiliary rail FKA14 landscape exten 1 coll



Worcester Part No.  
7 739 300 447

Flat roof support FKF5 landscape basic 1 coll



Worcester Part No.  
7 739 300 456

Flat roof support FKF6 landscape exten 1 coll

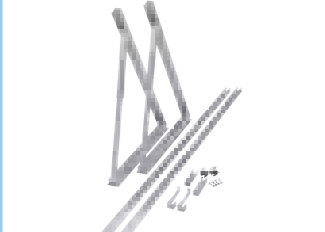

Worcester Part No.  
7 739 300 457

Slate/crown tile hook



Worcester Part No.  
7 739 300 281

Additional crown tile hook



Worcester Part No.  
7 739 300 282

TDS10 solar controller



Worcester Part No.  
7 739 300 378

Solar pump station



Worcester Part No.  
7 739 300 377

Expansion vessel 25L



Worcester Part No.  
7 739 300 119

Expansion vessel 35L



Worcester Part No.  
7 739 300 120

Solar fluid 25L



Worcester Part No.  
7 739 300 057

Solar fluid 10L



Worcester Part No.  
7 739 300 058

Expansion vessel connector



Worcester Part No.  
7 739 300 331

System pump filter\*



Worcester Part No.  
7 739 300 365

Solar service kit



Worcester Part No.  
7 739 300 397

Solar panel cover



Worcester Part No.  
7 739 300 399

Solar system filling pump



Worcester Part No.  
7 739 300 398

Greenskies 180 Cylinder



Worcester Part No.  
7 716 192 554

Greenskies 210 Cylinder



Worcester Part No.  
7 716 192 555

Greenskies 250 Cylinder



Worcester Part No.  
7 716 192 556

Greenskies 300 Cylinder



Worcester Part No.  
7 716 192 557

\*Must be used in conjunction with solar system filling pump.

# Solar parts ordering

## FKC-1S standard portrait panels

FKC-1S standard portrait panels								
Part number	Description	Most common package items	On roof		Flat roof		In roof	
			2 panel kit	3 panel kit	2 panel kit	3 panel kit	2 panel kit	3 panel kit
7739300422	FKC-1S Solar panel FKC-1S	2	2	3	2	3	2	3
7739300424	FKT-1S Solar panel FKT-1S							
7739300436	FKA3 Solar roof hook kit	2						
7739300281	FKA9 Slate/crown tile hook		2 sets of hooks as applicable to roof type	3 sets of hooks as applicable to roof type				
7739300282	FKB4Z Additional crown tile hook							
7739300439	FKA4 Bolt fixing kit corrugated							
7747002438	FS55 Collector connector FKC on roof	1	1	1				
7747002439	FS56 Collector connector FKC in roof						1	1
7747002440	FS57 Collector connector FKC flat roof				1	1		
7747002441	FS58 Collector connector FKT flat roof							
7747002442	FS59 Collector connector FKT on/in roof							
7739300432	ELT5 Air vent FKC	1	1	1	1	1	1	1
7739300433	ELT6 Air vent FKT							
7739300440	FKA5 Roof bar kit	1	1	1				
7739300441	FKA6 Roof bar kit 2nd panel	1	1	2				
7739300378	TDS10 Solar controller	1	1	1	1	1	1	1
7739300377	AGS2 Solar pump station	1	1	1	1	1	1	1
7739300119	SAG25 Expansion vessel 25L	1	1	1	1	1	1	1
7739300331	AAS1 Expansion vessel connector	1	1	1	1	1	1	1
7739300057	WFT25 Solar fluid 25L	1	1	1	1	1	1	1
7739300454	FKF3 Flat roof stand				1	1		
7739300455	FKF4 Flat roof stand 2nd panel				1	2		
7739300463	FKI5 In roof kit for 2 panels						1	1
7739300464	FKI6 In roof kit for additional panels							1

## FKT-1S high performance portrait panels

FKT-1S high performance portrait panels								
Part number	Description	Most common package items	On roof		Flat roof		In roof	
			2 panel kit	3 panel kit	2 panel kit	3 panel kit	2 panel kit	3 panel kit
7739300422	FKC-1S Solar panel FKC-1S							
7739300424	FKT-1S Solar panel FKT-1S	2	2	3	2	3	2	3
7739300436	FKA3 Solar roof hook kit	2						
7739300281	FKA9 Slate/crown tile hook		2 sets of hooks as applicable to roof type	3 sets of hooks as applicable to roof type				
7739300282	FKB4Z Additional crown tile hook							
7739300439	FKA4 Bolt fixing kit corrugated							
7747002438	FS55 Collector connector FKC on roof							
7747002439	FS56 Collector connector FKC in roof							
7747002440	FS57 Collector connector FKC flat roof							
7747002441	FS58 Collector connector FKT flat roof				1	1		
7747002442	FS59 Collector connector FKT on/in roof	1	1	1			1	1
7739300432	ELT5 Air vent FKC							
7739300433	ELT6 Air vent FKT	1	1	1	1	1	1	1
7739300440	FKA5 Roof bar kit	1	1	1				
7739300441	FKA6 Roof bar kit 2nd panel	1	1	2				
7739300378	TDS10 Solar controller	1	1	1	1	1	1	1
7739300377	AGS2 Solar pump station	1	1	1	1	1	1	1
7739300119	SAG25 Expansion vessel 25L	1	1	1	1	1	1	1
7739300331	AAS1 Expansion vessel connector	1	1	1	1	1	1	1
7739300057	WFT25 Solar fluid 25L	1	1	1	1	1	1	1
7739300454	FKF3 Flat roof stand				1	1		
7739300455	FKF4 Flat roof stand 2nd panel				1	2		
7739300463	FKI5 In roof kit for 2 panels						1	1
7739300464	FKI6 In roof kit for additional panels							1

## FKC-1W standard landscape panels

FKC-1W standard landscape panels							
Part number	Description	Most common package items	On roof		Flat roof		
			2 panel kit	3 panel kit	2 panel kit	3 panel kit	
7739300423	FKC-1W Solar panel FKC-1W	2	2	3	2	3	
7739300425	FKT-1W Solar panel FKT-1W						
7739300436	FKA3 Solar roof hook kit	2					
7739300281	FKA9 Slate/crown tile hook		2 sets of hooks as applicable to roof type	3 sets of hooks as applicable to roof type			
7739300282	FKB4Z Additional crown tile hook						
7739300439	FKA4 Bolt fixing kit corrugated						
7747002438	FS55 Collector connector FKC on roof	1	1	1			
7747002439	FS56 Collector connector FKC in roof						
7747002440	FS57 Collector connector FKC flat roof						
7747002441	FS58 Collector connector FKT flat roof				1	1	
7747002442	FS59 Collector connector FKT on/in roof						
7739300432	ELT5 Air vent FKC	1	1	1	1	1	
7739300433	ELT6 Air vent FKT						
7739300442	FKA7 Roof bar kit landscape panel	1	1	1			
7739300443	FKA8 Roof bar kit 2nd landscape panel	1	1	2			
7739300378	TDS10 Solar controller	1	1	1	1	1	
7739300377	AGS2 Solar pump station	1	1	1	1	1	
7739300119	SAG25 Expansion vessel 25L	1	1	1	1	1	
7739300331	AAS1 Expansion vessel connector	1	1	1	1	1	
7739300057	WFT25 Solar fluid 25L	1	1	1	1	1	
7739300456	FKF5 Flat roof stand landscape					1	1
7739300457	FKF6 Flat roof stand 2nd landscape panel					1	2
7739300488	FKI11 In roof kit for 2 landscape panels						
7739300489	FKI12 In roof kit for additional landscape panels						

## FKC-1W standard landscape panels

FKC-1W standard landscape panels							
Part number	Description	Most common package items	In roof		Wall mounted		
			2 panel kit	3 panel kit	2 panel kit	3 panel kit	
7739300423	FKC-1W Solar panel FKC-1W	2	2	3	2	3	
7739300425	FKT-1W Solar panel FKT-1W						
7739300436	FKA3 Solar roof hook kit						
7739300281	FKA9 Slate/crown tile hook						
7739300282	FKB4Z Additional crown tile hook						
7739300439	FKA4 Bolt fixing kit corrugated						
7747002438	FS55 Collector connector FKC on roof						
7747002439	FS56 Collector connector FKC in roof	1	1	1			
7747002440	FS57 Collector connector FKC flat roof						
7747002441	FS58 Collector connector FKT flat roof				1	1	
7747002442	FS59 Collector connector FKT on/in roof						
7739300432	ELT5 Air vent FKC	1	1	1	1	1	
7739300433	ELT6 Air vent FKT						
7739300442	FKA7 Roof bar kit landscape panel						
7739300443	FKA8 Roof bar kit 2nd landscape panel						
7739300378	TDS10 Solar controller	1	1	1	1	1	
7739300377	AGS2 Solar pump station	1	1	1	1	1	
7739300119	SAG25 Expansion vessel 25L	1	1	1	1	1	
7739300331	AAS1 Expansion vessel connector	1	1	1	1	1	
7739300057	WFT25 Solar fluid 25L	1	1	1	1	1	
7739300456	FKF5 Flat roof stand landscape					1	1
7739300457	FKF6 Flat roof stand 2nd landscape panel					1	2
7739300488	FKI11 In roof kit for 2 landscape panels	1	1	1			
7739300489	FKI12 In roof kit for additional landscape panels			1			

# Solar parts ordering

## FKT-1W high performance landscape panels

FKT-1W high performance landscape panels							
Part number	Description	On roof			Flat roof		
		Most common package items	2 panel kit	3 panel kit	2 panel kit	3 panel kit	
7739300423	FKC-1W Solar panel FKC-1W						
7739300425	FKT-1W Solar panel FKT-1W	2	2	3	2	3	
7739300436	FKA3 Solar roof hook kit	2	2 sets of hooks as applicable to roof type	3 sets of hooks as applicable to roof type			
7739300281	FKA9 Slate/crown tile hook						
7739300282	FKB4Z Additional crown tile hook						
7739300439	FKA4 Bolt fixing kit corrugated						
7747002438	FS55 Collector connector FKC on roof						
7747002439	FS56 Collector connector FKC in roof						
7747002440	FS57 Collector connector FKC flat roof						
7747002441	FS58 Collector connector FKT flat roof				1	1	
7747002442	FS59 Collector connector FKT on/in roof	1	1	1			
7739300432	ELT5 Air vent FKC						
7739300433	ELT6 Air vent FKT	1	1	1	1	1	
7739300442	FKA7 Roof bar kit landscape panel	1	1	1			
7739300443	FKA8 Roof bar kit 2nd landscape panel	1	1	2			
7739300378	TDS10 Solar controller	1	1	1	1	1	
7739300377	AGS2 Solar pump station	1	1	1	1	1	
7739300119	SAG25 Expansion vessel 25L	1	1	1	1	1	
7739300331	AAS1 Expansion vessel connector	1	1	1	1	1	
7739300057	WFT25 Solar fluid 25L	1	1	1	1	1	
7739300456	FKF5 Flat roof stand landscape				1	1	
7739300457	FKF6 Flat roof stand 2nd landscape panel				1	2	
7739300488	FKI11 In roof kit for 2 landscape panels						
7739300489	FKI12 In roof kit for additional landscape panels						

## FKT-1W high performance landscape panels

FKT-1W high performance landscape panels					
Part number	Description	In roof		Wall mounted	
		2 panel kit	3 panel kit	2 panel kit	3 panel kit
7739300423	FKC-1W Solar panel FKC-1W				
7739300425	FKT-1W Solar panel FKT-1W	2	3	2	3
7739300436	FKA3 Solar roof hook kit				
7739300281	FKA9 Slate/crown tile hook				
7739300282	FKB4Z Additional crown tile hook				
7739300439	FKA4 Bolt fixing kit corrugated				
7747002438	FS55 Collector connector FKC on roof				
7747002439	FS56 Collector connector FKC in roof				
7747002440	FS57 Collector connector FKC flat roof				
7747002441	FS58 Collector connector FKT flat roof			1	1
7747002442	FS59 Collector connector FKT on/in roof	1	1		
7739300432	ELT5 Air vent FKC				
7739300433	ELT6 Air vent FKT	1	1	1	1
7739300442	FKA7 Roof bar kit landscape panel				
7739300443	FKA8 Roof bar kit 2nd landscape panel				
7739300378	TDS10 Solar controller	1	1	1	1
7739300377	AGS2 Solar pump station	1	1	1	1
7739300119	SAG25 Expansion vessel 25L	1	1	1	1
7739300331	AAS1 Expansion vessel connector	1	1	1	1
7739300057	WFT25 Solar fluid 25L	1	1	1	1
7739300456	FKF5 Flat roof stand landscape			1	1
7739300457	FKF6 Flat roof stand 2nd landscape panel			1	2
7739300488	FKI11 In roof kit for 2 landscape panels	1	1		
7739300489	FKI12 In roof kit for additional landscape panels		1		

# A complete after-sales service

As part of the worldwide Bosch Group, Worcester strives to maintain the highest possible standards of after-sales care.

In addition to the no-nonsense parts and labour warranty applicable to all Worcester boilers, you and your customers have the assurance that every Worcester boiler is manufactured to both the appropriate British and European standards.

### Worcester Contact Centre

Should you require support, our fully trained Contact Centre staff, based at our head office in Worcester, are ready to take your calls. Whatever your query our contact centre operators along with our nationwide team of engineers are ready to help you.

### Boiler Protection Options

Worcester offers boiler protection including service and maintenance contracts. Please call the Worcester Contact Centre for further details.

If you do not offer annual service and maintenance contracts please refer your customers to the Worcester Contact Centre:

**Tel: 08457 256 206**

**Fax: 01905 757 536**

### Opening Times

Monday – Friday: 7.00am – 10.00pm

Saturday: 8.00am – 5.00pm

Sunday: 9.00am – 12 noon

## All the technical advice you need

### Spares

Genuine replacement parts for all Worcester boilers are readily available from stock, on a next day delivery basis. For more information please call your local stockist. You can find a spares stockist on our website.

### Customer Technical Support

The Worcester Technical Helpline is a dedicated phone line – committed to providing a comprehensive service to complement the brand name and quality of our boiler products. Our experienced team of technical experts provides answers to queries of a technical nature across the entire Worcester range.

Worcester also has a pre-sales department, which provides assistance in selecting a boiler system to suit a particular application, along with full guidance on installation. As well as this we will also assist in finding a recommended installer. For more information please contact the Technical Helpline or alternatively visit our website where literature can be downloaded at [www.worcester-bosch.co.uk](http://www.worcester-bosch.co.uk)

### Technical

**Tel: 08705 266 241**

**Fax: 01905 752 741**

### Opening Times

Monday – Friday: 7.00am – 8.00pm

Saturday: 8.30am – 4.00pm

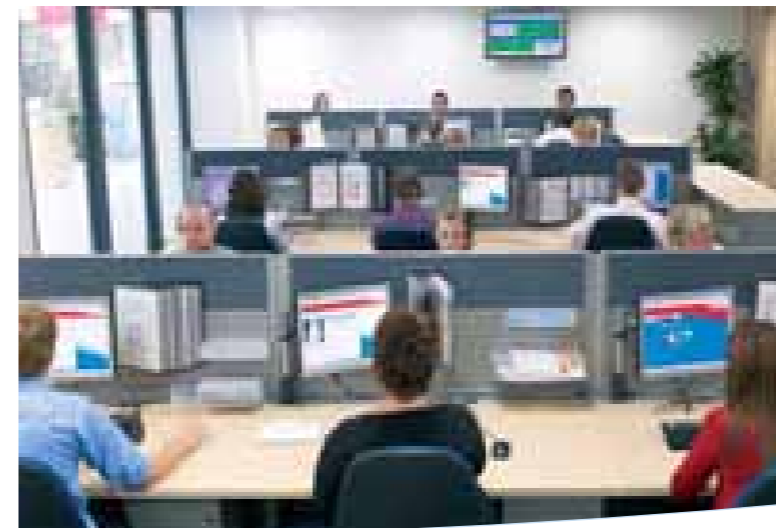

# The very best training programmes from Worcester

Worcester has always placed great emphasis on technical support and training for installers and service engineers. Today this need is greater than ever. The differences between a combi, conventional and system boiler are substantial, and the technology of each continues to advance at a rapid pace.

To ensure the highest levels of competence and expertise in the installation of all Worcester products, the company runs intensive training courses for installers, commissioning engineers and engineers involved with servicing and fault finding.

## Courses available

Our training facilities offer a number of courses suitable for the installer and commissioning engineers, and a more in-depth course for the servicing and fault finding engineers.



## Training Centres throughout the UK

Worcester's network of regional training centres are strategically located across the country and include the 'A' Rated Training Academy at the company's headquarters. This facility has recently been extended to include an oil-fired appliance workshop and a renewable energies workshop in addition to the extensive gas-fired training facilities.

In addition to these outstanding facilities there are centres at Clay Cross in Derbyshire and Bangor in Northern Ireland. Further 'A' Rated Academies are open at West Thurrock in Essex and Bradford in West Yorkshire as well as additional training opportunities available throughout the UK. Please phone 01905 752526 for more information about a course near you. Each course is run by specialist trainers and is superbly equipped to deliver a combination of classroom theory and practical hands-on experience that's second to none.

## College-linked Learning

A number of the UK's leading proactive technical colleges are equipped with Worcester products and offer excellent practical tuition on a more local level.

## Distance Learning/Web Based Learning

Worcester has produced a selection of Distance Learning CD ROMs/DVDs which are packed with information. Call 01905 752556 for your copies, or visit [www.worcester-bosch.co.uk](http://www.worcester-bosch.co.uk) for information on Web Based Learning.

## Mobile training

Our 7.5 tonne mobile oil training vehicle with working boilers, is now available throughout the country for hands-on oil training and OFTEC courses.

Courses on Air to Water and Air to Air are now available please check with your local TSM and the Worcester website [www.worcester-bosch.co.uk](http://www.worcester-bosch.co.uk). Phone 01905 752526 to book your place.

Get on course for a more profitable future now.

Call now for more information  
01905 752526



[www.worcester-bosch.co.uk](http://www.worcester-bosch.co.uk)



# Worcester training courses

Worcester training courses	
<b>Greenstar CDi and Highflow CDi gas-fired condensing combi boilers</b>	
Models covered	Greenstar 27/30/37/42CDi Greenstar Highflow 440/550CDi
Duration	1 day
<b>Greenstar i Junior and Si gas-fired condensing combi boilers</b>	
Models covered	Greenstar 24/28i Junior Greenstar 25/30Si
Duration	1 day
<b>Greenstar system and regular gas-fired condensing boilers</b>	
Models covered	Greenstar 12/15/18/24Ri Greenstar 30/40CDi Conventional Greenstar FS 30/42CDi Regular Greenstar 30CDi System Greenstar 12/24i System
Duration	1 day
<b>Greenstar Camray high efficiency condensing oil-fired boilers</b>	
Models covered	Greenstar Camray (kitchen) Greenstar Camray (kitchen) System Greenstar Camray Utility Greenstar Camray Utility System Greenstar Camray External
Duration	1 day
<b>Greenstar Danesmoor &amp; Heatslave high efficiency condensing oil-fired boilers</b>	
Models covered	Greenstar Danesmoor Greenstar Utility Greenstar Heatslave Greenstar Heatslave External
Duration	1 day
<b>OFTEC Training</b>	
<b>OFTEC 101</b>	
Covering	Domestic/Light Commercial Pressure Jet Commissioning and Servicing
Duration	3 day course (2 days training plus 1 days assessment)
<b>OFTEC 105e</b>	
Covering	Domestic/Light Commercial Pressure Jet Boiler Installation
Duration	1 day assessment
<b>OFTEC 101 &amp; 105e</b>	
Covering	Domestic/Light Commercial Pressure Jet Installation, Commissioning and Servicing
Duration	3 day course (2 days training plus 1 days assessment comprising 2 theory and 1 practical)
<b>OFTEC 600a</b>	
Covering	Oil Tank Installation and Associated Controls
Duration	1 day assessment course
<b>OFTEC 101/105e/600e</b>	
Covering	Domestic/Light Commercial Pressure Jet Boiler Installation, Commissioning, Servicing and Oil Tank Installation and Associated Controls
Duration	4 days (2 days training and 2 days assessment)
<b>Mobile OFTEC</b>	
All above covered throughout the country on the mobile training vehicle as well as in all our centres.	

<b>Certificate in Energy Efficiency for Domestic Heating Course</b>	
Covering	Key elements of energy-efficient heating and hot water systems and products, compliance with the latest Building Regulations, how condensing boilers work and how they differ to non condensing products.
Duration	1 day
<b>Unvented Cylinder Course</b>	
Covering	All G3 Regulations for the Installation, Servicing and Commissioning of Unvented Cylinders. The course includes recognised accreditation by Logic Certification.
Duration	1 day
<b>Greenskies Solar System</b>	
Covering	Installation, Commissioning and Servicing The course includes recognised accreditation by Logic Certification for eligibility of low carbon buildings programme funding.
Duration	2 days
<b>Greenstore Ground Source Heat Pumps</b>	
Covering	Installation, Commissioning and System Design
Duration	2 days
<b>Greenstore Heat Pumps – Air to Water</b>	
Covering	Installation, Commissioning and System Design
Duration	2 days
<b>Greenstore Heat Pumps – Air to Air</b>	
Covering	Installation, Commissioning and System Design
Duration	1 day



## Useful numbers

### Sales

Tel: 01905 752640  
Fax: 01905 456445

### Service

Tel: 08457 256206  
Fax: 01905 757536  
Livingston (Scotland)  
Fax: 01506 441687

### Spare Parts

Tel: 01905 752576  
Fax: 01905 754620

### Training

Tel: 01905 752526  
Fax: 01905 752535

### Technical (Pre & Post Sales)

Tel: 08705 266241  
Fax: 01905 752741

### Literature Line

Tel: 01905 752556  
or download instantly  
from our website

# [www.worcester-bosch.co.uk](http://www.worcester-bosch.co.uk)



The Council for  
Registered Gas  
Installers



Member



In partnership with



energy saving trust™



Worcester, Bosch Group is a brand name of Bosch Thermotechnology Ltd.

This leaflet is accurate at the date of printing, but may be superseded and should be disregarded if specification and/or appearances are changed in the interest of continued improvement. The statutory rights of the consumer are not affected.

Part No. 8 716 110 080 E 09/08



BBT1624



Worcester, Bosch Group,  
Cotswold Way, Warndon,  
Worcester, WR4 9SW

Tel: 01905 754624 Fax: 01905 754619